

# Operating Instructions

## Self-Test Electronics

All models ordered with the self-test option provide:

- ❑ Visual indication of AC power status
- ❑ Visual Indication of all self-diagnostic test cycles
- ❑ Visual indication of unit malfunctions including:
  - Battery fault
  - Charger fault
  - Transfer fault
  - Lamp fault
- ❑ User initiated test cycles of 1, 5, 30 or 60 minutes
- ❑ Temperature compensated charger for longer battery life
- ❑ 15 minute retransfer delay

## LED Indicators

Two Status LED indicators, one red and one green, are provided on the control panel of all models equipped with the self-test option.

### Red Service Alert LED

Under normal operating conditions, the Service Alert LED indicator will remain off. In the event the Controller detects a malfunction, the Service Alert LED will blink at a 1 Hz. rate based on the following table:

SERVICE ALERT CODES	
●	= battery disconnected
● - ●	= battery fault
● - ● - ●	= charger fault
● - ● - ● - ●	= transfer fault
● - ● - ● - ● - ●	= lamp fault

Red Status LED Code	Description
One blink ON/pause	Battery not connected
Two blinks ON/pause	Battery fault
Three blinks ON/pause	Charger fault
Four blinks ON/pause	Transfer circuit fault
Five blinks ON/pause	Emergency Lamp Fault

### Green Operating Status LED

The green Operating Status LED serves as both an AC power and a self-test indicator. During normal operation, the Operating Status LED will be illuminated indicating the presence of AC power. During all automatic or manual self-test cycles, the Operating Status LED will blink at a 1 Hz. rate.

<b>operating status</b>
<b>on = ready</b>
<b>off = ac off</b>
<b>blinking = test in process</b>

## Manual Tests

Using the unit test switch, users can initiate different duration test cycles based on the following table:

Initiating Action	Test Cycle
Press test switch once	1 minute
Press test switch twice	5 minute
Press test switch 3 times	30 minute
Press test switch 4 times	60 minute

**NOTE:** Pressing test switch at any time after a test cycle has begun cancels remainder of test and returns unit to normal operation.

## Lamp Sensing Adjustment

### Procedures

In order for the electronics module to detect a lamp failure in any of the connected lighting heads, the lamp sensing circuit must be adjusted in the following manner:

### 2-Head Self Contained Models

All 2-head models are supplied with the lamp sensing circuit factory set and do not require any adjustment.

### Load Jumper Setting - CV3 Models

CV3 self-test models are capable of operating a total of three lighting heads and are shipped from the factory with a load sensing jumper provided as shown in position "A" of Fig. 1 below. In this position, the diagnostic circuitry can sense a failure in any of the unit's three connected lamps (2 integral and 1 remote).

### IMPORTANT

If the third (remote) lighting head is not to be connected (for the purpose of extended run time or other reasons), the load sensing jumper must be reinstalled as shown in Position "B" below to prevent a false lamp failure indication. With the jumper in this position, the unit circuitry is enabled to sense a failure in either of the unit's two integral lamp heads

**Fig 1. Load Jumper Settings - CV3 Models**

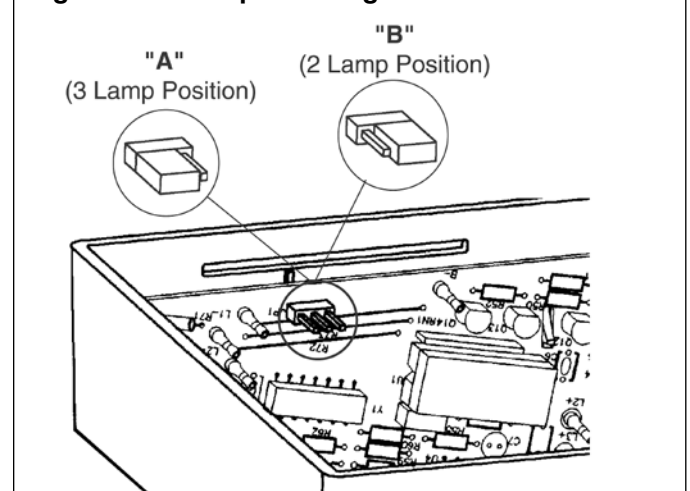

### Lamp Sense Adjustment - CV5 Models

CV5 remote capacity models provide sufficient battery power to operate the unit's two integral lighting heads plus up to three more remote lighting fixtures.

1. With a small screwdriver, turn the Lamp Sense Adjust potentiometer fully **clockwise**. (See Fig. 2 on back)

# Self-Test/Self-Diagnostic Electronics Option Operating Instructions (Cont.)

**Fig. 2**      **Charger Distribution Board**

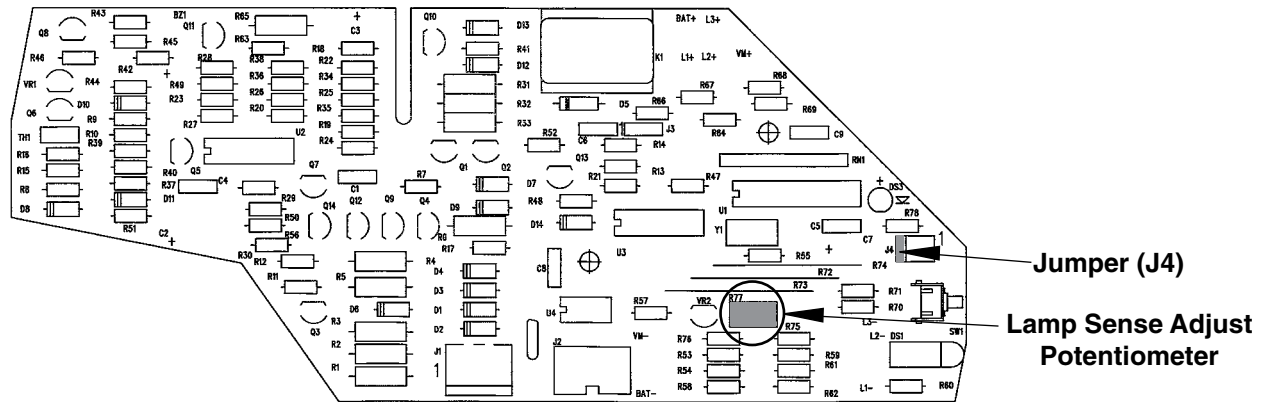

2. Press the unit test switch once. The emergency lamps will illuminate and a 1 minute self-test will begin. The green "Operating Status" LED on the unit's control panel will also begin to flash. The "Lamp Fail" LED located on the charger/distribution board (see Fig. 1) should not be illuminated at this time.
3. Slowly turn the "Lamp Sense Adjust" potentiometer **counterclockwise** until the "Lamp Fail" LED on the charger/distribution board illuminates. Then turn the adjustment pot back clockwise **just slightly beyond** the point where the "Lamp Fail" LED turns off to avoid false failure indications. At this point, the red "Service Alert" LED on the unit's control panel will begin a repetitive cycle of flashing 5 times followed by a pause ("lamp fault" service alert).
4. While the self-test is still in progress, disconnect one of the remote emergency lamps. The "Lamp Fail" LED on the charger/distribution board should turn on. Reconnect the lamp and observe that the "Lamp Fail" LED goes out. If "Lamp Fail" LED remains illuminated, turn the "Lamp Sense Adjust" potentiometer fully clockwise and repeat step 3.
5. Allow the 1 minute self-test to end (or press the test switch again to cancel self-test cycle).
6. Press the test switch again. Verify that the "Lamp Fail" LED and the "Service Alert" LED are not illuminated.

"Operating Status" LED, located on the display panel, illuminates to indicate the presence of AC power. The unit's red "Service Alert" LED will blink after application of AC power if the battery connection is not completed. During normal operation, the unit's charging circuit maintains the battery at full capacity and the Controller constantly monitors charger performance. Should the terminal voltage vary from design parameter values, the unit's red "Service Alert" LED will blink, indicating a malfunction of the battery or charger. Upon interruption of normal AC power, or brownout condition, the Controller automatically switches the emergency lighting load to the battery. Emergency power will be provided for a minimum of 90 minutes. During emergency operation, the battery is protected from deep discharge by a low voltage battery disconnect circuit. Upon return of normal AC power, a 15 minute retransfer delay holds the unit in emergency operation mode allowing utility voltage to stabilize prior to reconnection. The charger will then begin a recharge cycle. A temperature compensated float type charger is provided in models with Lead-Calcium batteries. This charger is designed to adjust charging voltage with changes in ambient temperature to maximize the life and performance of the unit's batteries. Models utilizing Nickel-Cadmium batteries require no temperature compensation as they utilize a constant current type charger design to maintain the unit's batteries. The charger will bring the battery to full capacity within acceptable U.L. time standards. The Controller automatically initiates a one minute discharge/diagnostic test every 28 days  $\pm$  3.5 hours and a 30-minute discharge/diagnostic test every 6 months  $\pm$  1 day. These tests exercise the unit's battery to optimize its capacity and allows the Controller to analyze emergency operation performance. Any malfunction of the unit's transfer circuit or emergency lamps will cause the red "Service Alert" LED on the unit's display panel to blink. During normal operation, all red "Service Alert" LED blinking indications of unit malfunction remain latched until corrected and retested. A manual test switch allows a user programmable 1, 5, 30 or 60-minute diagnostic/discharge test at any time. During all automatic and user initiated self-tests, the unit's green "Operating Status" LED will blink to indicate a diagnostic cycle in process.

**Important: CV5 Models Without Connected Remote Lighting Heads**

If for the purpose of an extended illumination period remote lighting heads will not be connected to the unit, simply **remove Jumper (J4) from the printed circuit board to prevent false lamp sense failure indications.** No further adjustment procedure is required in this application.

**Note:** If remote lamps are connected to the unit at any time, re-install Jumper (J4) and follow **Lamp Sense Adjustment** procedure

**Operation**

Self-testing/self-diagnostic operation is fully automatic. Accidental discharge of the unit battery prior to energization is prevented by an AC lockout circuit. The unit's green