

Taking A Unit Out Of Service

If a unit is to be deliberately taken out of service for an extended period, the positive (+) battery lead should be disconnected from the charger/transfer module and insulated so that the battery will go into storage in a fully charged condition.

Replacing A Battery

1. De-energize the AC power.
2. Disconnect battery leads from charger module.
3. Release battery retaining strap (Fig. 1). Remove battery.
4. Replace with a new battery (see unit model label for correct part number).
5. Reassemble the unit.

Replacing An Emergency Lamp

1. Remove diffuser lens from lamp housing by prying lens adjacent to tab slot
2. Remove and replace lamp (refer to product for specific lamp type)..

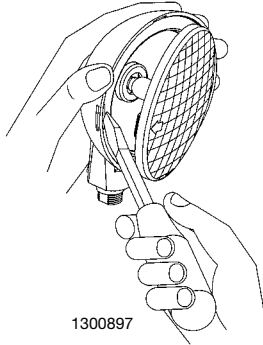

1300897

**RECYCLING INFORMATION**

All steel, aluminum and thermoplastic parts are recyclable.

NOTICE: Emergency units contain rechargeable batteries which must be recycled or disposed of properly.

**EZ-2R Series**

Twin-Head Recessed Emergency Lighting Unit
Standard and Spectron® Equipped Models
Installation, Operation and Service Instructions

**IMPORTANT SAFEGUARDS**

When using electrical equipment, basic safety precautions should always be followed including the following.

READ AND FOLLOW ALL SAFETY INSTRUCTIONS

1. Do not use outdoors.
2. Do not let power supply cords touch hot surfaces.
3. Do not mount near gas or electric heaters.
4. Equipment should be mounted in locations and at heights where it will not readily be subject to tampering by unauthorized personnel.
5. The use of accessory equipment not authorized by the manufacturer may cause an unsafe condition.
6. Do not use this equipment for other than its intended purpose.
7. Servicing of this equipment should be performed by qualified service personnel.
8. Test cycling: the Life Safety Code (NFPA 101) requires testing of emergency lighting units once a month for a minimum of 30 seconds, and once a year for a minimum of 90 minutes.

INSTALLER:

- **SEE UNIT LABEL FOR ADDITIONAL MODEL SPECIFICATIONS**
- **SAVE THESE INSTRUCTIONS FOR USE BY OWNER/OCCUPANT**

WARNING – This product contains chemicals known to the State of California to cause cancer, birth defects and/or other reproductive harm. Thoroughly wash hands after installing, handling, cleaning, or otherwise touching this product.

1300897
1300906

INSTALLATION

General Instructions

This unit is designed for recess mounting in a wall or ceiling. Provide each unit with a single unswitched supply from a 120VAC or 277VAC branch circuit used for normal lighting in the area to be protected.

Fig. 1

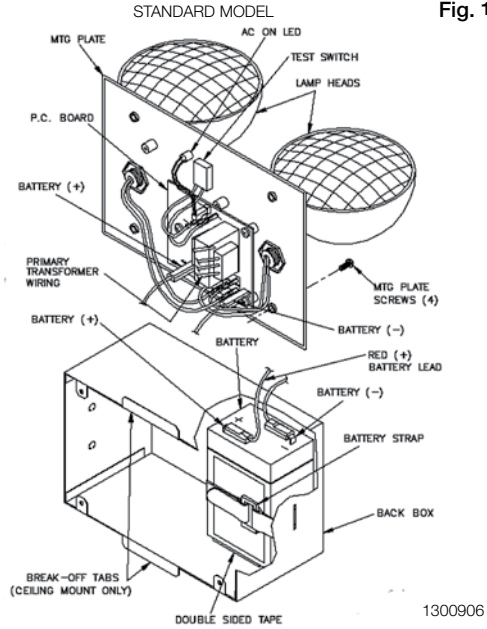

Fig. 1 SPECTRON SELF-TEST/SELF-DIAGNOSTIC MODEL

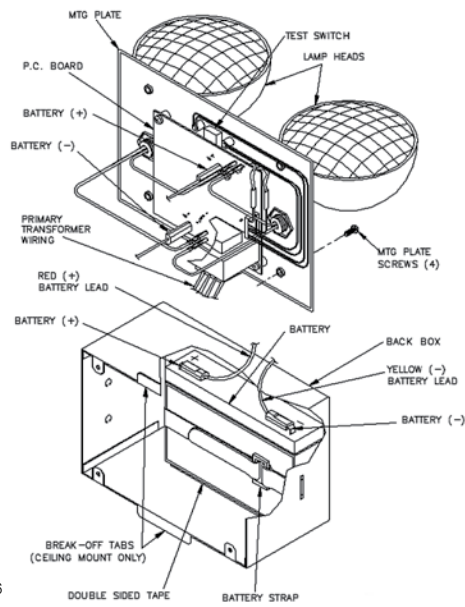

Fig. 2

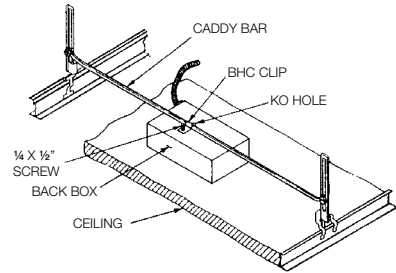
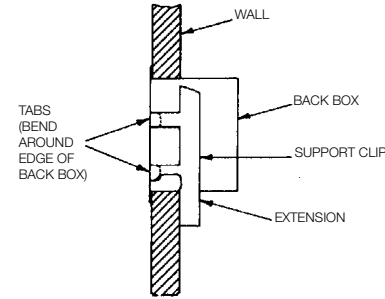

Fig. 3



Installing The Unit: Ceiling Mounting

1. Attach back box to caddy bar (model F-CBM accessory, sold separately) by sliding BHC clip into KO in the rear of the back box. Thread large 1/4 X 1/2" screw from inside back box through BHC clip (Fig. 2)
2. Remove two break off tabs (Fig. 1) located in front center of two sides of back box.
3. Remove one KO and use standard hardware to attach cable conduit.
NOTE: Do not remove KO's on battery side. Do not remove KO's not used for cable connections.
4. Cut opening in ceiling panel and install panel in suspended ceiling grid. From adjacent opening, secure caddy bar/back box assembly to ceiling "T" bars.
5. Adjust caddy bar slot height so that front edge of back box is 1/16" from lower edge of ceiling tile.
6. Remove protective top layer of tape from side of battery. Slide battery into cabinet so that exposed side of tape contacts side of cabinet. Secure battery with strap.
7. Connect yellow leads from printed circuit board to battery negative (-). Connect red lead from printed circuit board to battery positive (+).
Caution: Damage to the battery may occur if the battery is left connected for a long period of time without AC power.
8. Make AC supply connections using mechanical wire connectors. Select either: black for 120VAC or red for 277VAC. Cut back and insulate unused lead.
9. Assemble mounting plate to back box using (4) mounting screws.
10. Readjust caddy bar, if needed, to bring mounting plate even with ceiling panel.
11. Adjust emergency lamps to desired angle.
12. Refer to Operation section.

Installing The Unit: Wall Mounting

1. Cut opening in wall to accept back box.
2. Remove one KO and use standard hardware to attach cable conduit.
NOTE: Do not remove KO's on battery side. Do not remove KO's not used for cable connections.
3. Position back box in wall opening.
4. Secure back box using supplied box support clips (Fig. 3). Position clips on sides of back box; be sure extensions rest securely against back surface of wall. Bend tabs tight against sides of back box.
5. Connect yellow leads from printed circuit board to battery negative (-). Connect red lead from printed circuit board to battery positive (+).
Caution: Damage to the battery may occur if the battery is left connected for a long period of time without AC power.
6. Make AC supply connections using mechanical wire connectors. Select either: black for 120VAC or red for 277VAC. Cut back and insulate unused lead.
7. Assemble mounting plate to back box using (4) mounting screws.
8. Adjust emergency lamps to desired angle.
9. Refer to Operation section.

OPERATION

"AC ON" LED is illuminated when AC power is present.

NOTE: All models are supplied with an AC Lockout circuit, which prevents the emergency lights from illuminating when the battery is connected and no AC power is present.

NOTE: All models are supplied with a Low Voltage Disconnect circuit, which prevents damage to the battery from deep discharge during prolonged emergency operation.

NOTE: Batteries are often shipped in a discharged state – this is normal. The battery will require charging. Allow several hours of charge before testing the unit.

Models With SPECTRON® Self-Testing/Self-Diagnostic Circuitry

Models equipped with the Spectron self-testing/self-diagnostic electronics system provide:

- Visual indication of AC power status
- Visual indication of self-diagnostic test cycles
- Visual indication of any unit malfunctions including—
- Battery fault
- Transfer Fault
- Charger fault
- Emergency Lamp fault

Spectron equipped units also include:

Brownout protection: unit will automatically transfer to emergency operation upon detection of low AC power (approximately 80% of nominal line).

Time Delay Retransfer: upon return of normal AC power, unit will remain in the emergency mode for an additional 15 minutes to allow AC power to stabilize.

LED Status Indicators

Two status indicators, one green and one red, are provided on the control panel of all models equipped with the Spectron option.

Green Operating Status LED

The green Operating Status LED serves as both an AC power and a self-test indicator. During normal operation, the green Operating Status LED will be illuminated, indicating the presence of AC power. During all automatic or manual self-test cycles, the green Operating Status LED will blink at a 1 Hz. rate.

Red Service Alert LED

Under normal operating conditions, the red Service Alert LED indicator will remain "off". In the event the Spectron controller detects a malfunction, the red Service Alert LED will blink at a 1 Hz. rate, based on the following table:

Red Status LED Code	Description
One blink ON/pause	Battery not connected
Two blinks ON/pause	Battery fault
Three blinks ON/pause	Charger fault
Four blinks ON/pause	Transfer circuit fault
Five blinks ON/pause	Emergency Lamp fault

Automatic Tests

The unit will automatically initiate a self-test/self-diagnostic cycle based on the following table:

Testing Period	Duration of Test
Once a month	1 minute
Once every 6 months	30 minutes

Manual Tests

Using the unit test switch, users can initiate different duration test cycles based on the following table:

Initiating Action	Test Cycle
Press test switch once	1 minute
Press test switch twice	5 minutes
Press test switch three times	30 minutes
Press test switch four times	60 minutes

Pressing the test switch at any time after a test cycle has begun cancels the remainder of the test and returns the unit to normal operation.