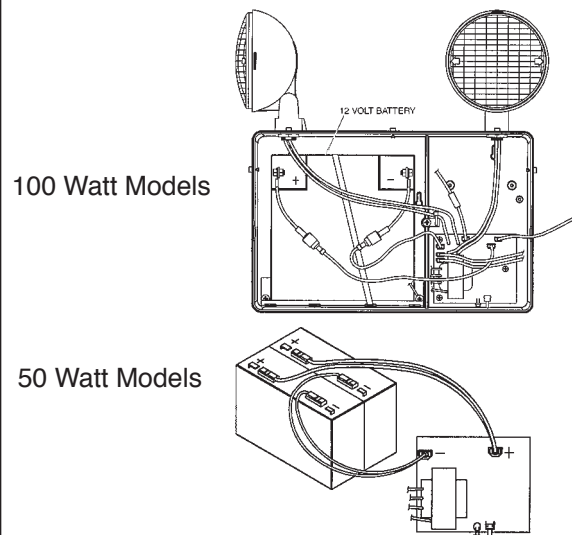
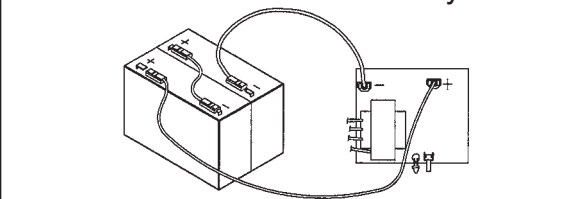

**Fig. 4** Single and Double Harness Lead Connections  
12V Lead-Calcium Battery Models



**Fig. 5** Single Harness Lead Connection  
6V Lead-Calcium Battery Models



**VOLTAGE DROP TABLE**

Total Watts on Wire Run	6 Volt System Wire Gauge				Total Watts on Wire Run	12 Volt System Wire Gauge			
	#12	#10	#8	#6		#12	#10	#8	#6
	Max. Length of Wire Run (Feet)					Max. Length of Wire Run (Feet)			
6	94	150	238	379	6	378	600	955	1518
7	81	129	204	325	7	324	515	818	1301
8	70	112	179	284	8	283	450	716	1138
10	56	90	143	227	10	226	360	570	910
12	44	70	112	178	12	178	283	450	715
14	40	64	102	162	14	162	257	409	650
16	33	53	84	134	16	133	212	338	538
18	30	47	75	119	18	119	189	300	477
20	28	45	71	114	20	113	180	286	455
21	27	43	68	108	21	108	171	273	434
24	24	38	60	95	24	89	141	225	357
25	21	34	54	86	25	86	136	216	344
30	19	30	48	76	30	75	120	190	303
35	15	25	39	63	35	65	103	164	260
40	13	21	33	53	40	53	85	135	214
48	11	17	28	44	48	44	70	112	178
50	11	17	27	43	50	43	68	108	172
75	7	11	18	29	75	28	45	72	115
100	5	8	14	21	100	21	34	54	86
125	4	7	11	17	125	17	27	43	69
150	3	5	9	14	150	14	23	36	57
175	3	5	8	12	175	12	19	31	49
200	2	4	6	10	200	10	16	27	42
225	2	4	6	10	225	10	16	25	40
250	2	3	5	9	250	9	14	22	36

**Fig. 6** Single and Double Harness Lead Connections - Nickel-Cadmium Battery Models

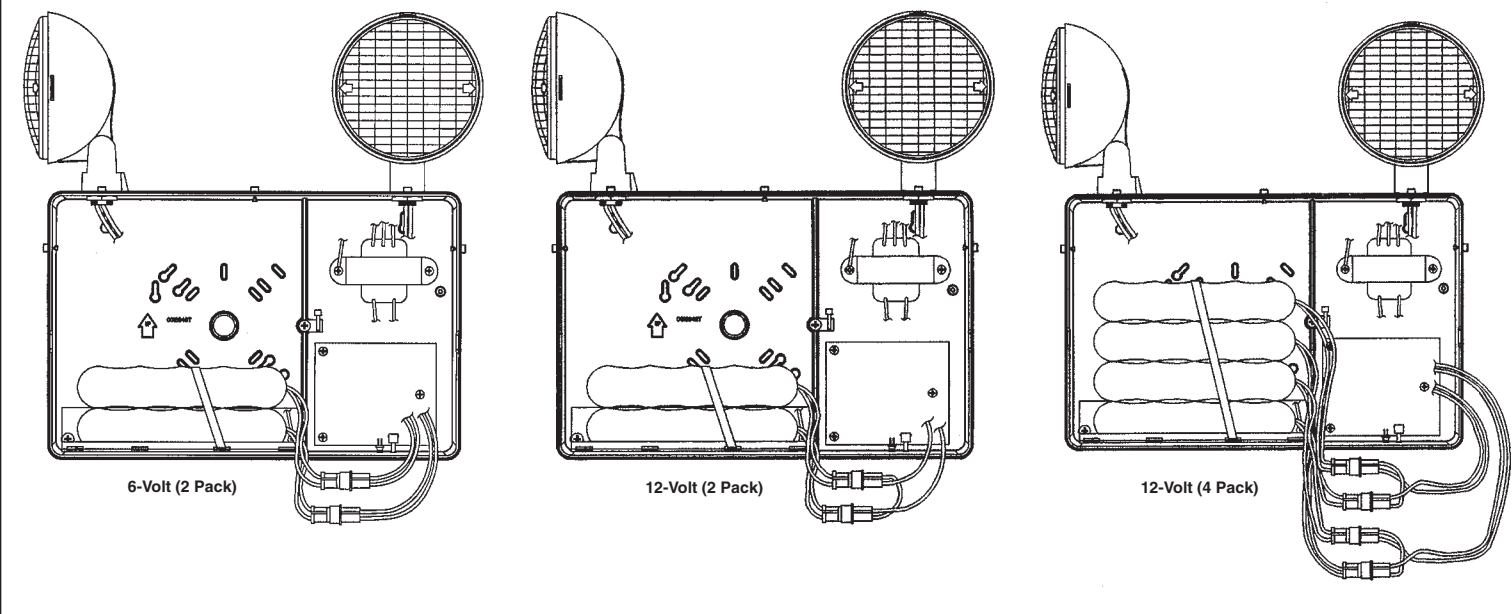

**NOTE:** Self-testing, self-diagnostic models with over 80 watts of capacity require a minimum load of 35 watts for accurate lamp failure indications.



**Models CVEC50, NVEC50, CVEC50-12V, NVEC50-12V, CVEC100-12V and NVEC100-12V**



**High-Capacity Emergency Lighting Units  
Installation Instructions For Standard,  
Remote Capacity And Damp Location Models**

**IMPORTANT SAFEGUARDS**

When using electrical equipment, basic safety precautions should always be followed including the following.

**READ AND FOLLOW ALL SAFETY INSTRUCTIONS**

1. Do not use outdoors.
2. Do not mount near heaters or hot surfaces.
3. Equipment should be mounted in locations and at heights where it will not readily be subject to tampering by unauthorized personnel.
4. The use of accessory equipment not authorized by the manufacturer may cause an unsafe condition.  
Caution: Halogen cycle lamps may be used in this equipment. Halogen cycle lamps operate at high temperatures. Do not store or place flammable materials near lamp. To avoid shattering: Do not operate lamp in excess of rated voltage. Protect lamp against abrasion and scratches and against liquids when operating. Dispose of lamp with care.
5. Do not use this equipment for other than its intended purpose.
6. Servicing of this equipment should be performed by qualified service personnel.

**SAVE THESE INSTRUCTIONS**

**EMERGENCY LIGHTING AND POWER EQUIPMENT FOR USE IN DAMP LOCATIONS**

Damp location listed units are suitable for use in:

1. Interior locations subject to moderate degrees of moisture, such as some basements, some barns, some cold-storage warehouses, and the like.
2. Partially protected locations under canopies, marquees, roofed open porches and the like.

**GENERAL INSTRUCTIONS**

This unit is designed for surface mounting on a wall or other solid surface (building support structure, column, etc.). Unit must be mounted high enough to maximize illuminated area under anticipated conditions of use. Be sure to allow ample clearance for mounting and aiming the lighting heads.

Provide each unit with a single unswitched power supply from a 120 or 277VAC branch circuit used for normal lighting in the same area. The wiring should be permanent installation, using appropriate size wire.

**Note:** De-energize AC circuit to unit during initial installation, and during servicing or relamping operations.

**PLACING THE UNIT IN SERVICE**

1. Remove housing cover (1) from housing (2).
2. Select two of the five lamp head knockouts (4) appropriate for the particular installation and attach lamp head (5) with nut (6). More heads may be added as an option. Connect lamp leads to circuit board (11).
3. Remove 7/8" knockout from the housing back (7) and two oblong knockouts corresponding with the junction box being used. For surface conduit, remove 7/8" knockout from top or side of housing and two keyway knockouts for mounting.
4. Secure housing (2) to junction box (or wall) with approved fasteners (not provided).

**Note:** For wall mounting, the embossed arrow on the rear of housing must point up. All fasteners should have a rated pullout of thirty (30) pounds minimum.

5. Identify unit as using either:

- Lead-Calcium batteries (8) [standard models, i.e.: NVEC50, NVEC50-12V, NVEC100-12V] or
- Nickel-Cadmium batteries (8) [model number ending with "N", i.e.: NVEC50N, NVEC50N-12V, NVEC100N-12V]

continued...



Hubbell Lighting, Inc.

- Connect remote lamps (if used) to blue (+, fused) and yellow (-) leads (10) (Fig. 2 or Fig. 3).
- Connect 120 or 277VAC input connections to transformer (Fig. 2 or Fig. 3). Connect green wire to building ground.

**Note:** insulate the unused transformer lead to prevent potential shock hazard.

Depending on the type of unit battery, follow steps 8 through 16 below.

#### • Units Supplied With Lead-Calcium Batteries

- Place battery (8) into housing (2).
- Determine proper battery orientation from Fig. 4 or Fig. 5 (single harness lead connection or double harness lead connection). Battery is positioned to the left of the circuit board.
- Connect positive (+, red) and negative (-, yellow) battery harness leads from printed circuit board to corresponding battery terminals as shown in Fig. 4 or Fig. 5.
- Check all wiring for loose or missing connections.
- Replace cover. Tighten cover screws.
- Aim lamp heads (5) to properly illuminate the path of egress.
- Energize unit with AC power.

**Note:** Allow unit to charge for 24 hours prior to performing initial test.

- Press and hold the "TEST" button (see Fig. 2 for "TEST" button location) to confirm illumination and proper aiming of emergency lamps. ("AC ON" indicator LED should go off). Release the "TEST" button; emergency lamps should extinguish. Normal operation begins.
- Normal Operation: with power supplied, "AC ON" LED indicator is illuminated and emergency lamps are off.

#### • Units Supplied With Nickel Cadmium Batteries

- Place battery (8) into housing (2).
- Determine proper battery orientation from Fig. 6 (single or double harness lead connections). Battery is positioned to the left of the circuit board.
- Connect battery harness leads from printed circuit board to corresponding battery harness leads as shown in Fig. 6.
- Check all wiring for loose or missing connections.
- Replace cover. Tighten cover screws.
- Aim lamp heads (5) to properly illuminate the path of egress.
- Energize unit with AC power.

**Note:** Allow unit to charge for 24 hours prior to performing initial test.

- Press and hold the "TEST" button (see Fig. 3 for "TEST" button location) to confirm illumination and proper aiming of emergency lamps. ("AC ON" indicator LED should go off). Release the "TEST" button; emergency lamps should extinguish. Normal operation begins.
- Normal Operation: with power supplied, "AC ON" LED indicator is illuminated and emergency lamps are off.

### ROUTINE TEST CYCLING

- Every three (3) months: If there has been no power failure, press and hold the "TEST" button for at least thirty (30) seconds to confirm emergency lamp operation. Release "TEST" button to return to battery charging mode.
- Once a year: Perform a full battery conditioning cycle by de-energizing the AC circuit to which the unit is connected, and allow the unit to operate for ninety (90) minutes on battery power. Following successful test, energize AC circuit to begin battery charging cycle.

### REPLACING EMERGENCY LAMPS AND BATTERIES

#### General

- De-energize the AC power supply to the unit.
- Remove enclosure cover.
- Disconnect positive (+, red) battery lead (Nickel cadmium models - disconnect battery and printed circuit board connectors).

#### • Replacing Unit Emergency Lamp

- Remove diffuser lens from lamp housing by prying lens adjacent to tab slot (see Fig.7)
- Remove and replace lamp. (refer to unit product label for specific lamp type)

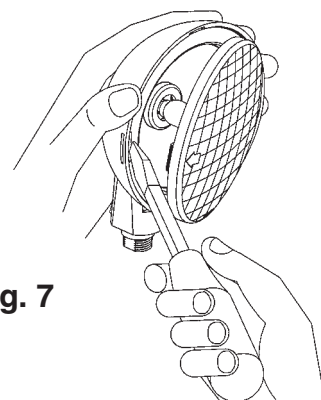

Fig. 7

#### • Replacing Unit Battery

- Remove defective battery. Recycle responsibly. Replace with genuine Dual-Lite/Cornerstone battery.
- Place new battery in enclosure. Make connections following steps outlined above.
- Test unit.

Fig. 1

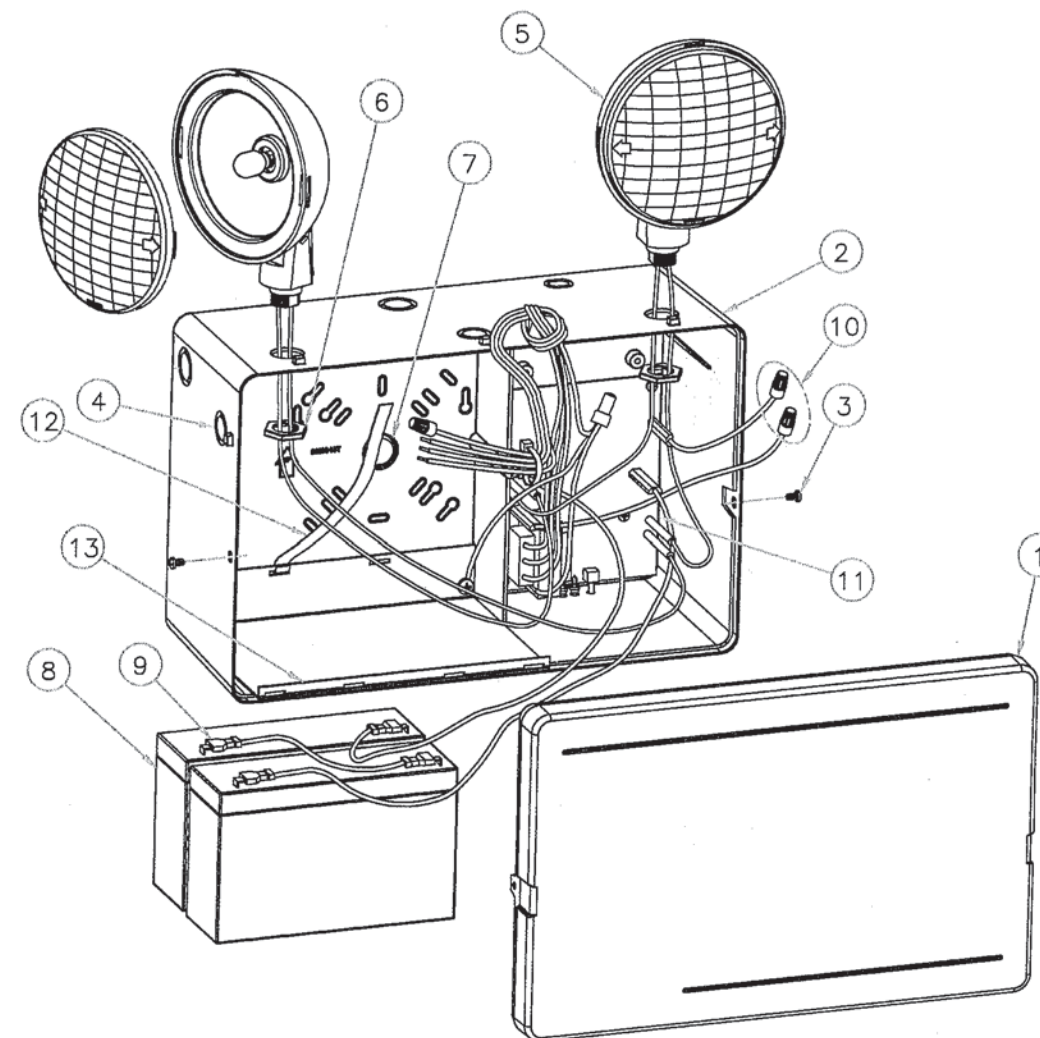

Fig. 2 Lead-Calcium Battery Models

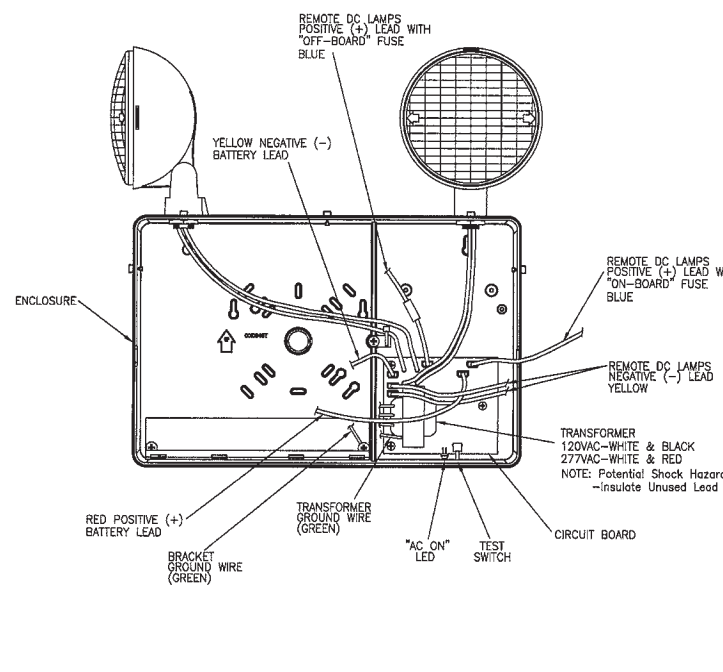

Fig. 3 Nickel-Cadmium Battery Models

