



DUAL LITE

# CENTRAL LIGHTING INVERTER SYSTEMS

AC Emergency Power  
Single / Three Phase  
Interruptible / Uninterruptible

DUAL-LITE LIFE SAFETY SOLUTIONS

# CENTRAL LIGHTING INVERTER

## ***SAFETY . . . RELIABILITY . . . VALUE***

In an emergency, life safety is the number one priority. By using central lighting inverters to power existing indoor and outdoor luminaires in lieu of self-contained emergency lights, occupants are more likely to evacuate to a public way in a safe and orderly fashion. Central lighting inverters not only make occupants feel more at ease during a crisis, but they also maintain the architectural integrity of the building and typically yield the lowest total cost of ownership during normal operation. Greater value – increased safety!



### **LIFE SAFETY CODE**

When interior or exterior lighting extinguishes due to an interruption in the normal power supply, the Life Safety Code (NFPA 101) requires egress pathway illumination, which can be provided by a Dual-Lite inverter system. This requirement includes illuminating both the path of egress from inside the building to the nearest exit point and from outside the building to the “public way.”

**According to the Life Safety Code, emergency pathway illumination is required for:**

Stairs

Ramps

Escalators

Aisles

Walkways

Exit passages

Corridors

Parking lots

Outdoor pathways

### **SAFETY . . . RELIABILITY . . . VALUE . . .**

**When compared to other emergency lighting solutions, Central Lighting Inverters are:**

- **Safer** than other emergency lighting solutions because they typically provide full lumen output of the luminaire resulting in higher emergency light levels.
- Are more **reliable** because they are centrally located for easy maintenance and have the capability to email test results or alarm conditions to maintenance personnel .
- Offer greater **value** by using existing light sources, which maintains architectural design.

Dual-Lite’s central lighting inverter product line offers both interruptible and non-interruptible emergency AC power systems in single- and three-phase configurations.

# PORTER SYSTEMS



**LiteGear**®



**SYNCHRON**



**LSN**

**LIFE SAFETY NETWORK**



**Irident**



# CENTRAL LIGHTING INVERTER

## ADVANTAGES OF A CENTRAL LIGHTING INVERTER SYSTEM

### FULL LUMEN OUTPUT

Occupants feel more at ease and are less likely to panic when emergency lighting is provided by existing luminaires. Central lighting inverters power designated luminaires to full lumen output during a power outage ensuring a bright, evenly illuminated path of egress in emergency situations.



### AESTHETICS

Using existing luminaires allows occupants to enjoy the original architectural intent and integrity while simultaneously satisfying life safety requirements.

### EASE OF INSTALLATION

In most installations a single central lighting inverter will provide code required power to the emergency lighting vs multiple fluorescent battery packs or unit equipment. This reduces the amount of time and labor required for initial installation.

### EASE OF MAINTENANCE

With a centrally located inverter system there is only one location for maintenance vs unit equipment which is located throughout the building, reducing maintenance time and labor costs.

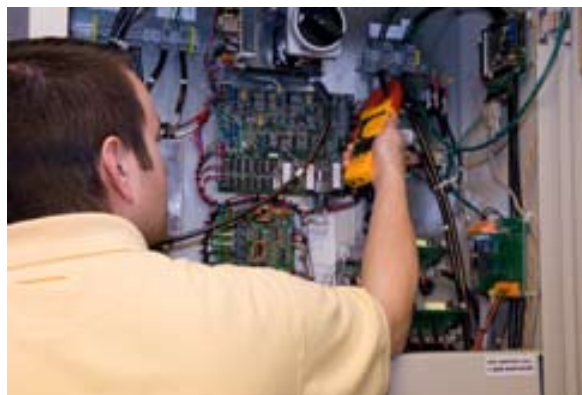

### HID COMPATIBILITY

Luminaires using HID lamp technology are often selected for a given lighting system because of their energy efficiency, long life and tolerance to high or low ambient temperatures. However, HID lamps are susceptible to voltage drops and have long re-strike times that could exceed life safety code requirements. Where HID luminaires are in use or being considered, an uninterruptible central lighting inverter is the ideal choice as an emergency AC power supply, even when an engine generator set is installed by code requirement. An uninterruptible power supply ensures voltage-sensitive loads, such as HID lamps, will operate normally as power transitions from utility power to emergency battery power to emergency generator power and back to normal utility power.



## OUTDOOR APPLICATIONS

In the absence of lighting due to an interruption in the normal power supply, the Life Safety Code calls for illumination of an egress pathway to safely guide building occupants to a “public way.” Some Authorities Having Jurisdiction (AHJs) will interpret a “public way” to include luminaires in outdoor applications. Inverters can remain located inside the building so cold or wet conditions that can impact performance, cost or life of the product are eliminated.

## AREA OF COVERAGE

The ability to generate the required level of illumination in large venues, such as stadiums or gymnasiums, is beyond the capability of most emergency lighting unit equipment. A properly sized central lighting inverter powering existing fixtures at full light output is the logical choice for these applications.



## AUXILIARY CRITICAL LOADS

In addition to providing emergency AC power for lighting loads, a central lighting inverter can also be used to provide emergency power for other critical equipment such as:

- Fire detection and protection equipment**
- Directional egress systems**
- Building management systems**
- Automated door mechanisms**
- Climate control systems**
- Patient care support functions**
- Security systems**
- Communications equipment**

## TOTAL COST OF OWNERSHIP

Dual-Lite realizes the initial price of an emergency lighting system is only one consideration when evaluating the total cost of ownership when comparing a centralized vs a decentralized emergency lighting system. Energy costs to operate the unit and annual maintenance expenses can significantly add to the total cost of ownership. Incorporating a central lighting inverter into your emergency lighting system will typically reduce your operating and maintenance costs to yield the lowest overall total cost of ownership. By incorporating energy efficient designs and intuitive interfaces with the latest in remote communications technology, Dual-Lite central lighting inverters are designed to lower the total cost of ownership even further.



# CENTRAL LIGHTING INVERTER

## COMPACT SINGLE-PHASE INVERTERS



### *LiteGear*<sup>®</sup>

Available with 100VA or 250VA capacity, Dual-Lite's LiteGear<sup>®</sup> compact central lighting inverters provide emergency AC power to existing indoor and outdoor lighting fixtures. The LiteGear<sup>®</sup> series is compatible with incandescent, compact fluorescent, linear fluorescent and LED lamped fixtures.



## FEATURES & BENEFITS OF LITEGEAR<sup>®</sup> INVERTERS

**AC LOCKOUT** - Prevents battery damage by shutting off DC battery power prior to AC power being supplied during installation.

**BROWNOUT PROTECTION** - Protects loads from low AC line voltage by automatically transferring the inverter to emergency mode to provide full output power.

**LOW VOLTAGE DISCONNECT** - Protects the batteries from damaging 'deep-discharge' conditions during prolonged power outages.

**MULTIPLE MOUNTING OPTIONS** - The compact size of LiteGear inverters allows the LG2 to be surface wall mounted while the LG1 may be surface wall, recessed wall, or recessed into a T-Grid ceiling.

**LED LAMP COMPATIBILITY** - LiteGear inverters are typically more cost effective than decentralized battery packs at providing emergency power to a luminaire, especially luminaires using today's LED lamp technology.

**GENERATION I STATUS & CONTROL INTERFACE -**

Two multipurpose LED indicators provide a simple, intuitive interface to notify the user of operating status.

### EXAMPLE APPLICATION

Interior or exterior egress lighting on multiple circuits with each circuit powered by a separate LiteGear.

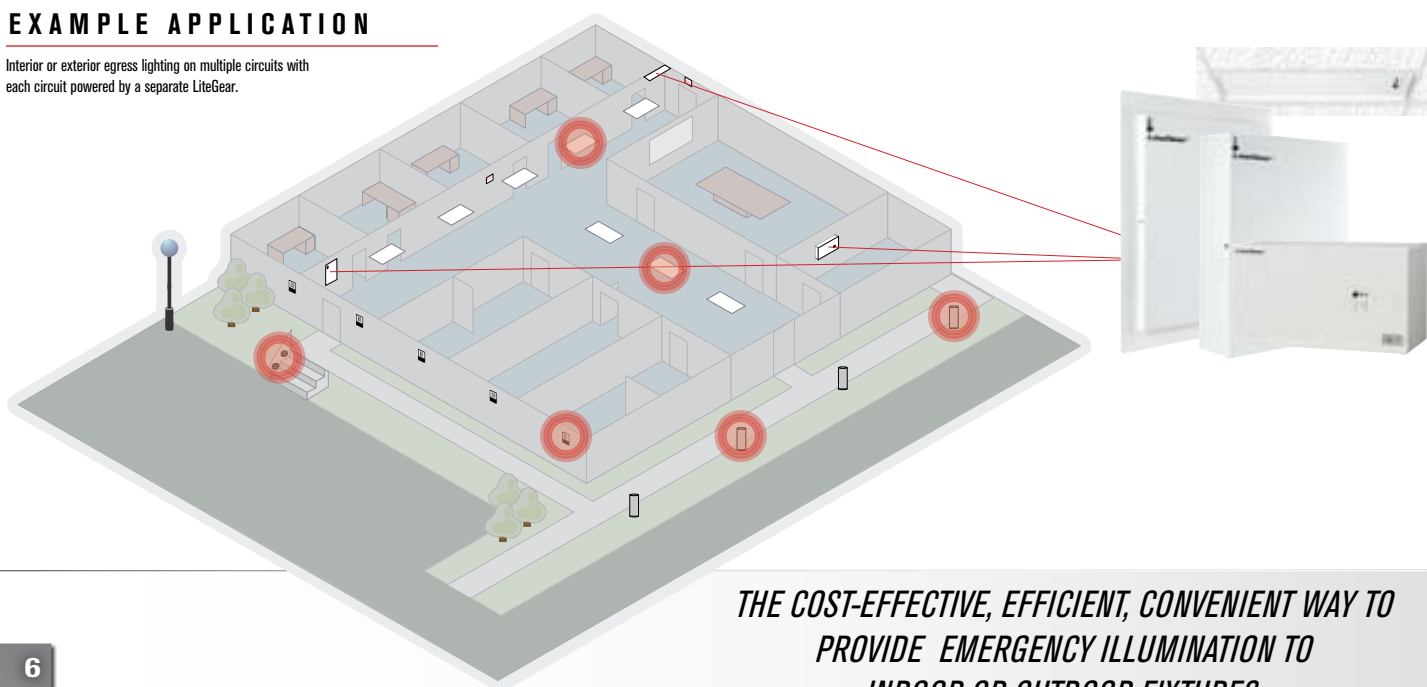

*THE COST-EFFECTIVE, EFFICIENT, CONVENIENT WAY TO PROVIDE EMERGENCY ILLUMINATION TO INDOOR OR OUTDOOR FIXTURES.*



## ORDERING GUIDE

<b>LG</b>	<b>2</b>	<b>S</b>
<b>Series</b>	<b>Capacity</b>	<b>Mounting</b>
	1 100 VA/W 2 250 VA/W <sup>2</sup>	S Surface Wall T Recessed Ceiling T-Grid <sup>1</sup> R Recessed Wall <sup>1</sup>

Ordering Notes:

1 Only available on 100 VA/W models.

2 Housing (LG2SLB) and batteries (0120935) ship in separate cartons.

## ACCESSORIES (Order Separately)

Model Number	Description
RTSLG	Remote Test Switch for LG2S
WGTW	Wire Gaurd for LG1S

## SPECIFICATIONS

Model Number	Input, Output Voltage	Enclosure Style	Total VA For 90 Minutes
LG1S	120/120 or 277/277	Surface Wall Mount	100
LG1R	120/120 or 277/277	Recessed Wall Mount	100
LG1T	120/120 or 277/277	Recessed Ceiling T-Grid	100
LG2S	120/120 or 277/277	Surface Wall Mount	250

## DIMENSIONS

LG1S Wall Mount Surface Model

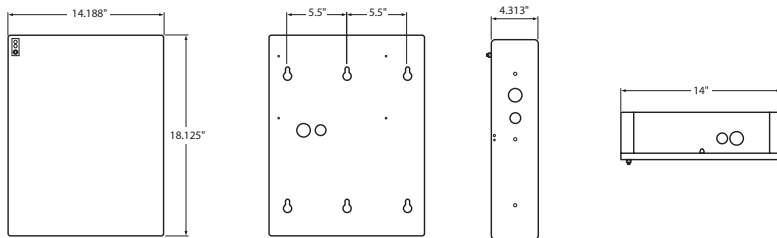

LG1T Recessed Ceiling T-Grid Model

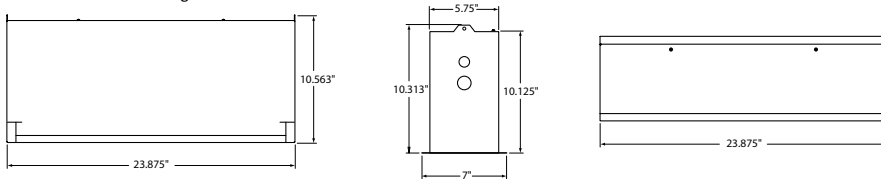

LG1R Wall Mount Recessed Model

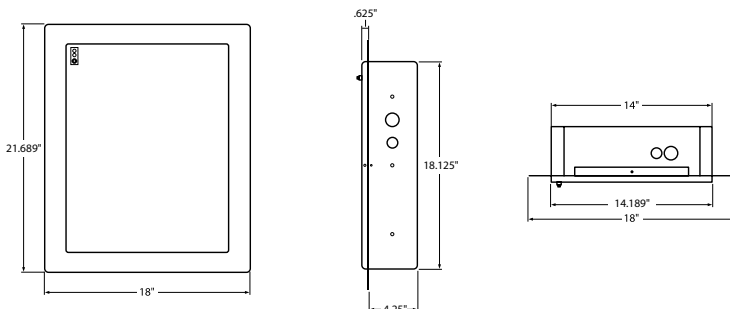

LG2S Wall Mount Surface Model

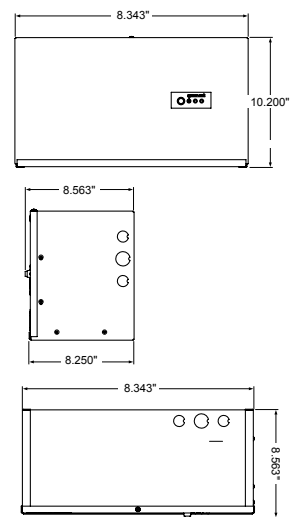

\* Consult your local sales representative or visit [www.dual-lite.com](http://www.dual-lite.com) for specification details and ordering information. The above illustrations are meant for visual reference purposes only, size may not be to scale.

# CENTRAL LIGHTING INVERTER

## SMALL SINGLE-PHASE INVERTER



### SYNCHRON

The Synchron single-phase inverter series provides true sine wave emergency power in ratings from 400 to 2100VA/Watts. Featuring true 'no-break' switching between utility and inverter power, all connected equipment will continue to operate normally under emergency conditions. The system mounts indoors and powers indoor or outdoor fixtures and other critical loads.

## FEATURES & BENEFITS OF SYNCHRON DLS SERIES INVERTERS

**OFFLINE TECHNOLOGY** - Continuously monitors input power conditions allowing the unit to operate with 98% efficiency translating to lower operating costs.

**HID COMPATIBILITY** - An instantaneous and synchronized transfer of power from normal to emergency mode ensures compatibility with HID lamp sources.

**TRUE SINE WAVE OUTPUT** - Sinusoidal waveforms yield less distortion and assure that voltage sensitive or frequency sensitive loads will operate normally during operation.

**PULSE WIDTH MODULATION** - High frequency digitally generated output waveform that results in greater efficiency, less heat, quieter operation and lower operating costs all within a compact design.

**SMALL FOOTPRINT** - The Synchron inverter system has one of the smallest footprints in the industry - less than 3 square feet! The small cabinet may be wall mounted.

**GENERATION II STATUS & CONTROL INTERFACE** - Three multipurpose LED indicators provide a simple, intuitive interface to notify the user of operating status as well as visual service alerts to operational malfunctions should they occur.

### EXAMPLE APPLICATION

Backing up egress linear fixtures and outdoor HID wallpacks

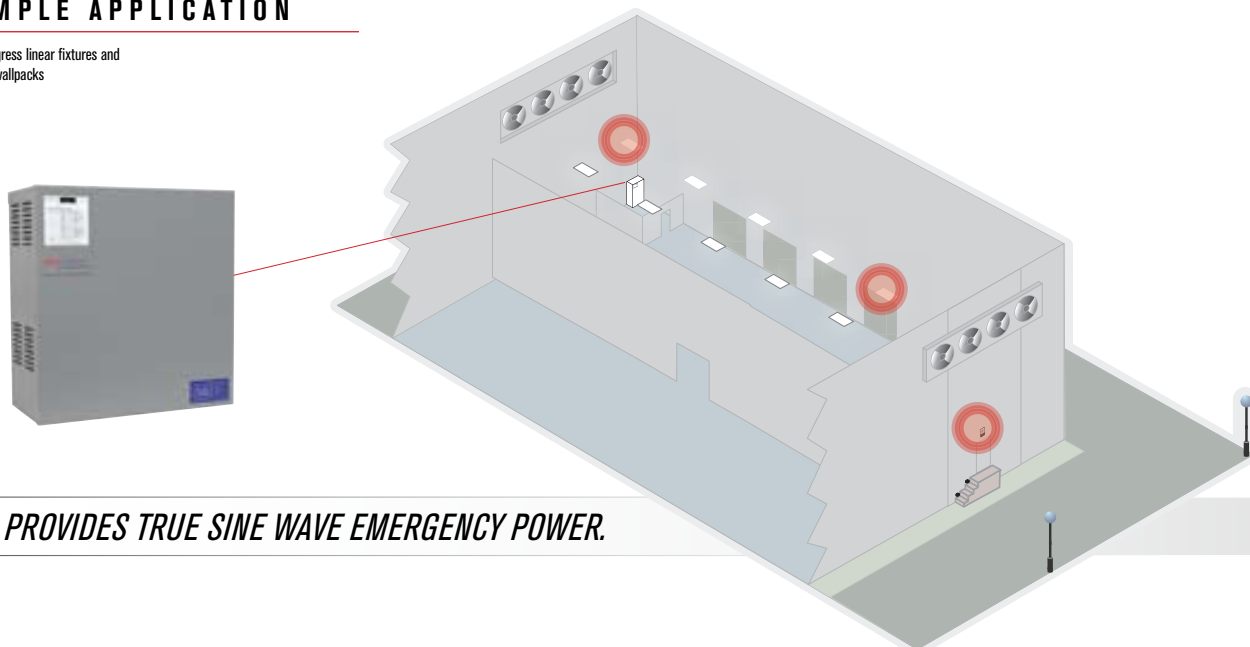

*PROVIDES TRUE SINE WAVE EMERGENCY POWER.*



## ORDERING GUIDE

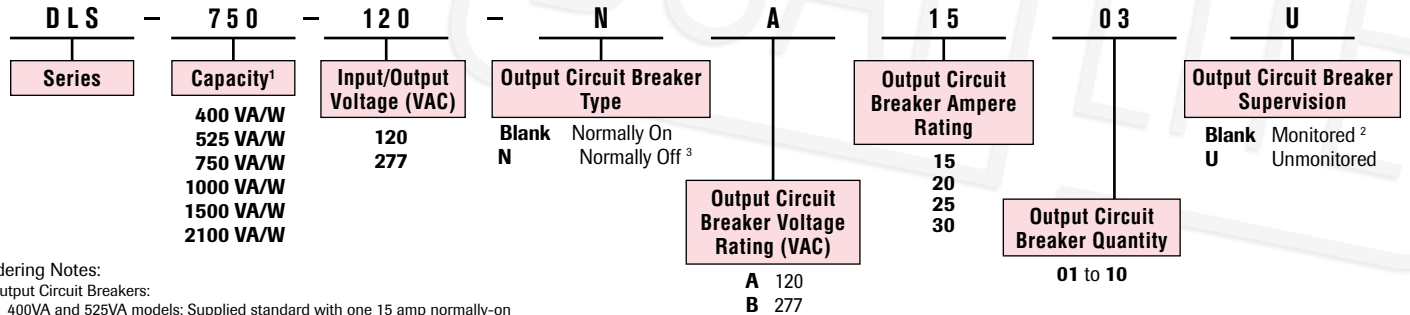

**Ordering Notes:**

- Output Circuit Breakers:
  - 400VA and 525VA models: Supplied standard with one 15 amp normally-on output circuit breaker.
  - 750VA through 2100VA models: Output circuit breakers are optional.
- A maximum of 6 monitored or 10 unmonitored normally-on circuit breakers may be specified.
- A maximum of 4 normally-off circuit breakers may be specified. Maximum rating of normally-off circuit breakers is 20 amperes. Normally-off output circuit breakers include a built-in, 15-minute retransfer delay to accommodate HID lighting loads.

## SPECIFICATIONS

VA/Watts	400	525	750	1000	1500	2100
<b>Power Factor Range</b>	.8 lead to .75 lag					
<b>AC Input Circuit Breaker Rating - 120/277V</b>	10/15 Amps			15/15A	20/15A	25/15A
<b>Charger Size</b>	2 Amps					
<b>System DC Voltage</b>	36		72		96	
<b>BTU/Hour - Line/Inverter</b>	70/260	92/341	131/382	175/510	263/765	368/886

## DIMENSIONS

750VA to 2100VA Models  
(floor mount only)

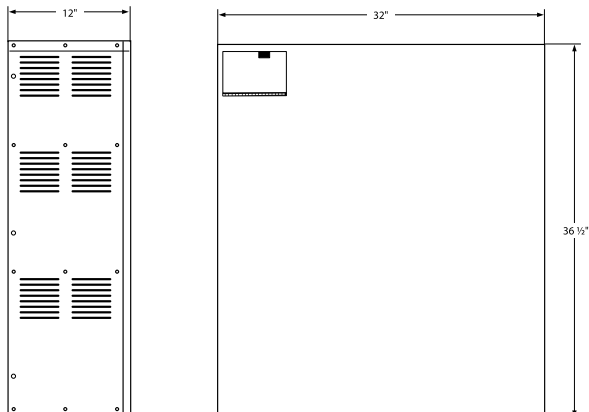
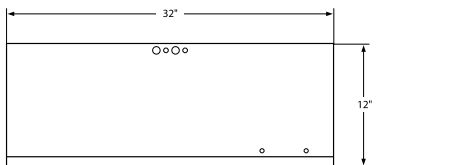

400VA to 525VA Models  
(may be wall mounted)

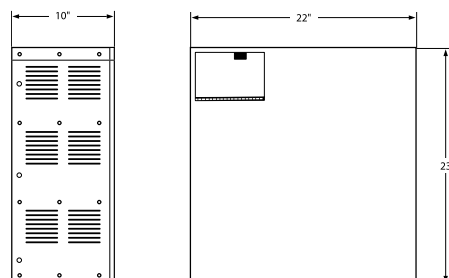
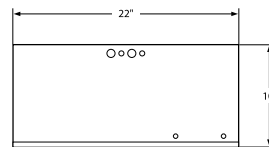

\* Consult your local sales representative or visit [www.dual-lite.com](http://www.dual-lite.com) for specification details and ordering information. The above illustrations are meant for visual reference purposes only, size may not be to scale.

# CENTRAL LIGHTING INVERTER

## MEDIUM SINGLE-PHASE INVERTER



**LSN**  
**LIFE SAFETY NETWORK**

This feature rich single-phase system includes self-test/self-diagnostic circuitry that complies with Life Safety Code testing and recording requirements, a two-line 40 character digital display and a user interface providing control of over 250 operating parameters. Dual-Lite's LSN D Series is available in capacity ratings of 1.0 through 17.5 KVA/KW.

## FEATURES & BENEFITS OF LSN D SERIES INVERTERS

**REMOTE COMMUNICATIONS** - All spectron LSN inverter systems are equipped with an RS232 communication interface designed to give the user greater flexibility in monitoring and controlling the system. Optional email capability sends pre-defined users alarm and test reports.

**ADVANCED BROWNOUT PROTECTION** - Dual-Lite's LSN boost tap regulation protects your loads from brownouts and recurrent low-voltage transients by sensing any drop in voltage and boosting the voltage back up to nominal without drawing current from the batteries and shortening their lives.

**SMALL FOOTPRINT** - Dual-Lite's LSN inverter system has one of the smallest footprints in the industry - less than 4 square feet for systems less than 5.0KVA!

**SECURITY** - To ensure that only authorized personnel can access the control functions or change any operating parameters, every LSN inverter comes standard with locked cabinetry and password protection.

### EXAMPLE APPLICATION

Powering interior high bay industrial fixtures and exhaust fan along with exterior HID path lighting on multiple circuits.

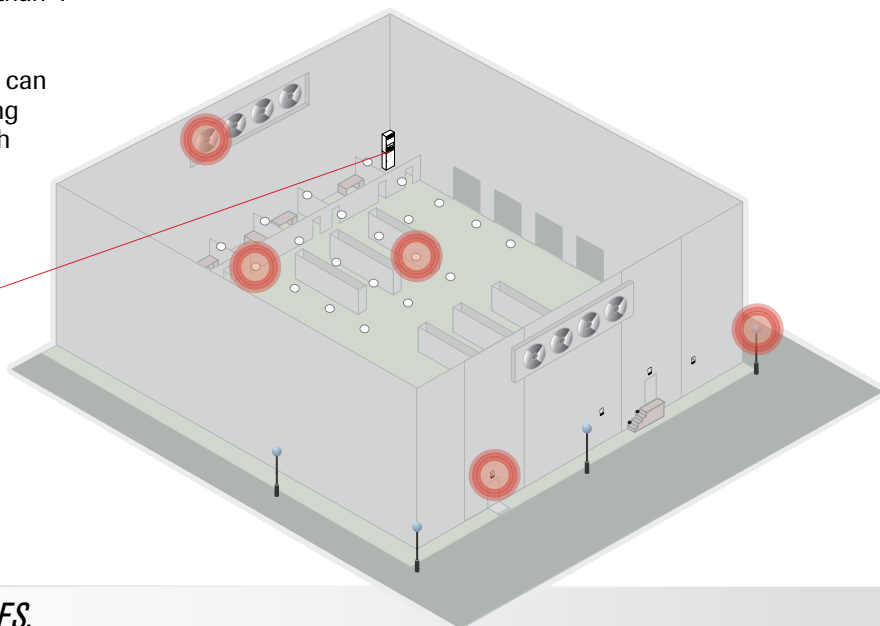

**SELF-TESTING/SELF-DIAGNOSTICS** - Electronics perform continuous testing of subsystems and lighting loads, ensuring performance to prescribed operating parameters.

**AUTOMATIC & PROGRAMMABLE RECORDING** - User-programmable discharge tests are performed and logged into memory for automatic NFPA 101 compliance.

**GENERATION II STATUS & CONTROL INTERFACE** - A 2-line x 40 character, microprocessor-controlled display located on the inverter cabinet's front door allows the user to monitor and control the inverter through the use of a menu-driven user interface



## ORDERING GUIDE

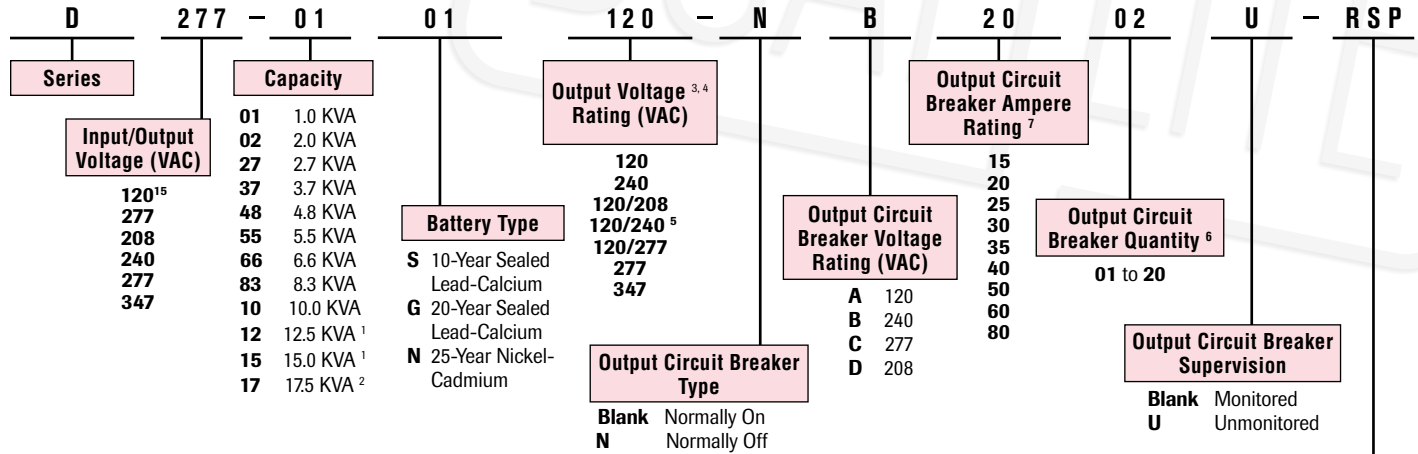

**Ordering Notes:**

- 1 Requires external transformer for 208VAC or 240VAC input.
- 2 277 and 347VAC input only.
- 3 Other voltages available. Consult factory.
- 4 External transformer may be required.
- 5 Loading may not exceed 50% of the system's total rating on any 120VAC leg.
- 6 Normally On circuit breakers: a maximum of 14 monitored, single pole positions or 20 unmonitored, single pole positions may be specified. Normally Off circuit breakers: a maximum of 8 single pole positions (monitored or unmonitored) may be specified.
- 7 Normally Off circuit breakers: a maximum rating of 20 amps.
- 8 The EPO option requires the SMT option.
- 9 Specify runtime in minutes when ordering. Example: AR120.
- 10 Available with 1.0, 2.0, 2.7, 3.7, 5.5, and 6.6KVA Series with S batteries only.
- 11 Available on 1.0 KVA - 4.8KVA Series.
- 12 Available on 5.5 KVA - 17.5KVA Series. Not available with 120V input on 6.6KVA and above. Not available with 208V input on 12.5 KVA and above. Not available with 240V input on 15.0 KVA and above.
- 13 Supplied in a wall mounted, NEMA 1 type enclosure. Cannot be used in systems with more than one single-pole output circuit breaker, on systems with different input and output voltages.
- 14 See System Configuration for 90-Minute Run Time.
- 15 Not available on 8.3KVA - 17.5KVA Series.

### Other Options & Accessories

**Options**

- EML** Email Device
- RSP** Remote Status Panel
- SMT** System Monitoring Terminal
- EPO** Emergency Power Off Terminal<sup>8</sup>
- AR** Alternate Runtime<sup>9</sup>
- SBC** Short Battery Cabinet<sup>10</sup>
- IBS** Internal Maintenance Bypass Switch (Make Before Break)
- C10** 10 Amp Charger Upgrade<sup>11</sup>
- C20** 20 Amp Charger Upgrade<sup>12</sup>
- CL60** Cabinet Locks

**Accessories**

- MBB** External Maintenance Bypass Switch (Make Before Break)<sup>13</sup>
- BBM** External Maintenance Bypass Switch (Break Before Make)<sup>13</sup>
- DSFK\_** Seismic Kit<sup>14</sup>

## DIMENSIONS

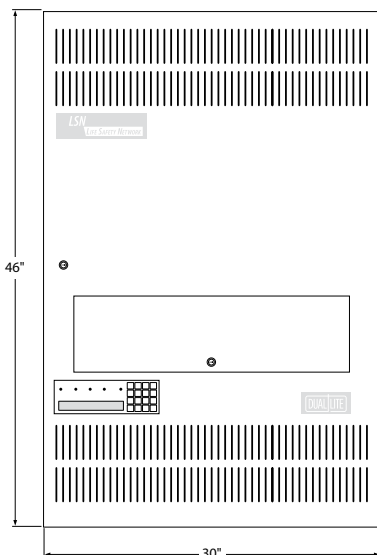

## Cabinet Configurations (90-Minute Runtime)

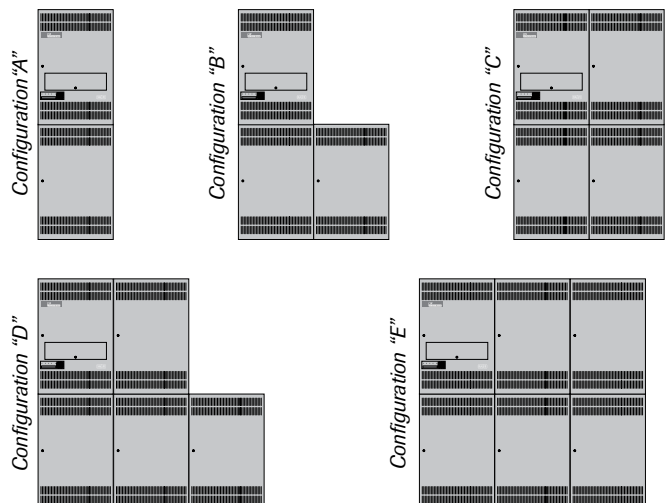

\* Consult your local sales representative or visit [www.dual-lite.com](http://www.dual-lite.com) for specification details and ordering information. The above illustrations are meant for visual reference purposes only, size may not be to scale.



# CENTRAL LIGHTING INVERTER

## LARGE THREE-PHASE INVERTERS



For larger installations, the Trident three-phase series is available in two sizes: the TRX has a capacity rating from 10 to 30KVA and the TRN has a capacity rating from 30 to 130 KVA. Trident's double-conversion design provides clean, regulated computer grade power in both normal and emergency operating mode. The Trident series offers the smallest three-phase system footprint currently available. The system mounts indoors and powers indoor or outdoor luminaires and other critical loads.

## FEATURES & BENEFITS OF TRIDENT INVERTERS

**DOUBLE CONVERSION TECHNOLOGY** - This online technology provides an electronic firewall that allows consistent and steady delivery of clean, filtered power to your critical loads.

**ADVANCED REMOTE COMMUNICATIONS** - Trident inverters are available with a variety of remote monitoring and communications options to report audible and visual signaling of status and alarm conditions using multiple protocols through Ethernet and/or web management tools.

### GENERATION IV STATUS & CONTROL INTERFACE -

The Trident series features a large, user-friendly, LCD graphic display for easy monitoring of operating parameters. Digital controls allow precise and custom programmable inputs to maximize operating efficiency and communications operations.

### EXAMPLE APPLICATION

Powering all interior and exterior egress lighting and EXIT signs on all three phases for the entire building.

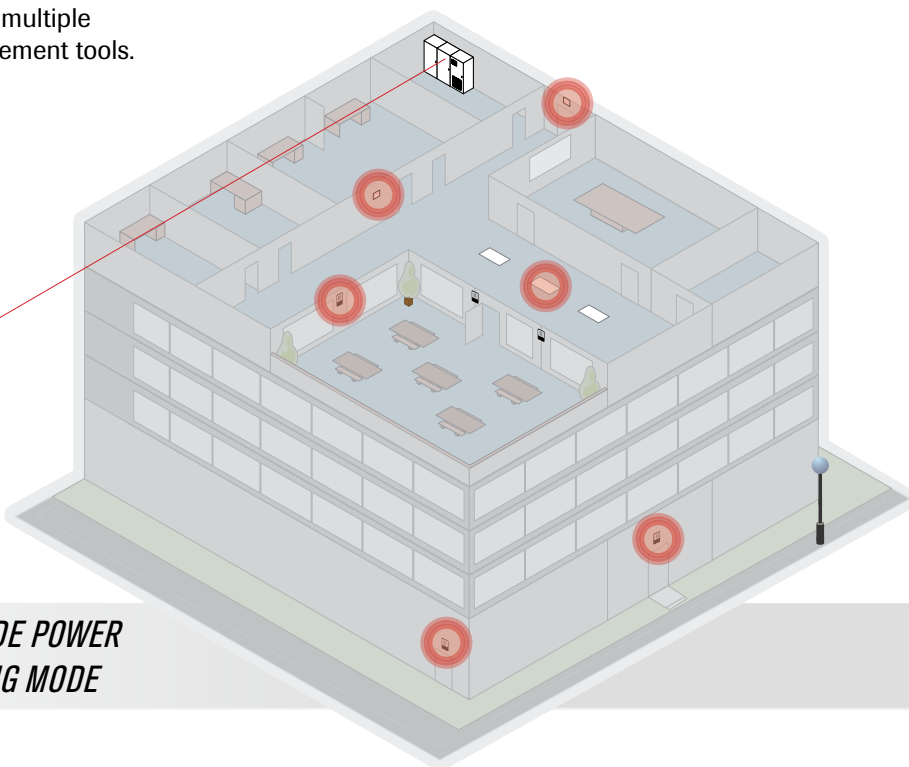

*PROVIDES CLEAN, REGULATED COMPUTER GRADE POWER  
IN BOTH NORMAL AND EMERGENCY OPERATING MODE*



## ORDERING GUIDES

<b>TRX</b>	-	<b>208</b>	-	<b>4</b>	-	<b>20</b>	-	<b>208</b>	-	<b>RSP</b>
<b>Series</b>		<b>Input Voltage (VAC)</b>		<b>Input Conductor</b>		<b>Capacity</b>		<b>Output Voltage<sup>1</sup> (VAC)</b>		<b>Options</b>
		208 480 600		3 3 Wire 4 4 Wire		10 10KVA/8KW 15 15KVA/12KW 20 20KVA/16KW 30 30KVA/24KW		208 480 600		<b>RSP</b> Remote Status Panel <b>SFK</b> Seismic Floor Kit <b>EXP</b> Export Package <b>FWT</b> Factory Witness Testing <b>FTR</b> Certified Factory Test Report <b>OWC</b> Open Communications Web Card <b>485</b> Open Communications 485 Web Card <b>IRB</b> Intel Slot relay Board <b>MBS</b> External Maintenance Bypass Switch <sup>2</sup>

**Ordering Notes:**

- 1 Output voltage must equal input voltage. Consult factory for different input and output voltages.
- 2 Circuit breakers are standard with all configurations except 208/208 4-conductor; Must order MBS to obtain circuit breakers for this configuration.

## DIMENSIONS

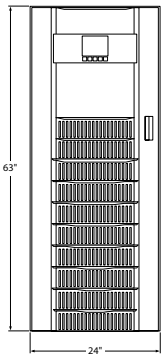

## Cabinet Configurations

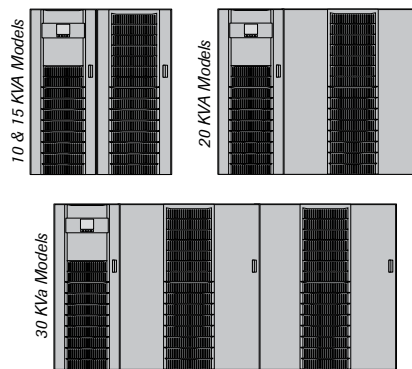

## ORDERING GUIDES

<b>TRN</b>	-	<b>208</b>	-	<b>4</b>	-	<b>20</b>	-	<b>208</b>	-	<b>RSP</b>
<b>Series</b>		<b>Input Voltage (VAC)</b>		<b>Input Conductor</b>		<b>Capacity</b>		<b>Output Voltage<sup>1</sup> (VAC)</b>		<b>Options</b>
		208 480		3 3 Wire 4 4 Wire		30 30KVA/24KW 40 40KVA/32KW 50 50KVA/40KW 65 65KVA/52KW 80 80KVA/64KW 100 100KVA/80KW 130 130KVA/104KW		208 480		<b>PRB</b> Programmable Relay Board <b>NIC</b> Network Interface Card <b>RSP</b> Remote Status Panel <b>ICI</b> Input Contact Isolator Board <b>DGF</b> DC Ground Fault Alarm <b>SFK</b> Seismic Floor Kit <b>DNC</b> Device Net Cable <sup>2</sup> <b>EXP</b> Export Package <b>FWT</b> Factory Witness Testing <b>FTR</b> Certified Factory Test Report <b>MBS</b> External Maintenance Bypass Switch <b>CB</b> I/O Circuit Breaker <sup>3</sup>

**Ordering Notes:**

- 1 Output voltage must equal input voltage. Consult factory for different input and output voltages.
- 2 Only available with RSP; must specify length in ft.
- 3 Must be ordered with MBS Option

## DIMENSIONS

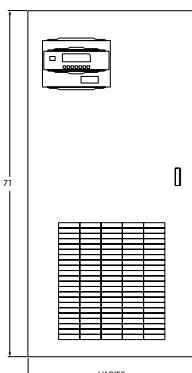

## Cabinet Configurations

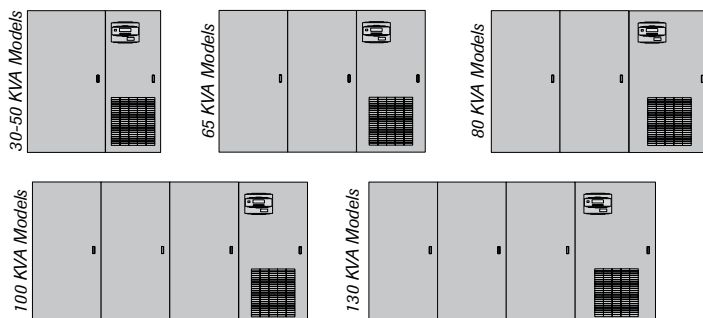

\* Consult your local sales representative or visit [www.dual-lite.com](http://www.dual-lite.com) for specification details and ordering information. The above illustrations are meant for visual reference purposes only, size may not be to scale.

# CENTRAL LIGHTING INVERTER

## FEATURES & OPTIONS COMPARISON



Features	Lite Gear	Synchron	LSN	Trident
<b>Power Capacity</b>	100-250 VA	400-2100 VA	1.0-17.5 KVA	10-130 KVA
<b>I/O Voltage</b>	120,277 VAC	120,277 VAC	120-347 VAC	208,480,600 VAC
<b>Phasing</b>	Single	Single	Single	Three
<b>AC Lockout</b>	•	•	•	•
<b>Brownout Protection</b>	•	•	•	•
<b>Low Voltage Disconnect</b>	•	•	•	•
<b>LED Lamp Compatibility</b>	•	•	•	•
<b>HID Compatibility</b>		•	•	•
<b>Offline Technology</b>	•	•	•	
<b>Small Footprint</b>	•	•	•	•
<b>True Sine Wave Output</b>		•	•	•
<b>Pulse Width Modulation</b>		•	•	•
<b>Advanced Brownout Protection</b>			•	•
<b>Security</b>			•	
<b>Self-Testing/Self Diagnostics</b>	Optional on 250VA		•	•
<b>Automatic &amp; Programmable Test Recording</b>			•	•
<b>Double Conversion Technology</b>				•
<b>Status &amp; Control Interface</b>				
<b>LED Indicator</b>	2	3	5	7+
<b>Test Button</b>	Gen I	Gen II	Gen III	Gen IV
<b>LCD Display</b>			Gen III	Gen IV
<b>Keypad</b>			Gen III	Gen IV
<b>Dynamic Line Diagram</b>				Gen IV
<b>Menu Driven Interface</b>				Gen IV
<b>Options</b>				
<b>Multiple Mounting Options</b>				
<b>Recessed Ceiling</b>	•			
<b>Recessed Wall</b>	•			
<b>Wall</b>	•	•		
<b>Floor</b>		•	•	•
<b>Remote Communications</b>				
<b>RS232 Interface</b>			•	•
<b>Email Interface</b>			•	
<b>Web Management Interface</b>				•
<b>Service &amp; Support</b>				
<b>Factory Startup</b>		•	•	•
<b>Additional Training Visit</b>		•	•	•
<b>Preventative Maintenance Program</b>		•	•	•
<b>Monitoring Program</b>			•	•

See specification sheets for detailed descriptions and additional options





## INVERTER SELECTION GUIDELINES

Sizing an inverter should be based on using peak current requirements rather than a sum of lamp wattages. To size an inverter properly for a 90 minute run time, simply do the following three steps:

- Determine the VA of each fixture or product (fixture voltage x fixture peak current)
- Sum up the VA of each product or fixture
- Select the next larger inverter as long as it incorporates a safety factor (typically x 1.25) for slight voltage drops, excess inrush current and for future expansion

Utilizing the chart to the left, check that the inverter capacity needed allows for the features that are required.

**EXAMPLE:** A warehouse uses HID luminaires for its lighting of which (12) luminaires need emergency power. Each fixture needing emergency power utilizes a 250 MH lamp and draws 1.1 Amps on a single phase line voltage of 277VAC.

**PROPER CALCULATION METHOD** -  $277 \text{ VAC} \times 1.1 \text{ Amps} \times 12 \text{ fixtures} \times 1.25 \text{ Safety Factor} = 4,571 \text{ VA}$  or 4.571 KVA total load requirement. In this case, one would select a 4.8KVA or larger LSN inverter.

**IMPROPER CALCULATION METHOD** -  $12 \text{ fixtures} \times 250 \text{ watts} = 3,000 \text{ VA}$  or 3.0 KVA total load requirement. In this case, one would have selected a 3.7KVA LSN inverter. Once installed, this system would probably have experienced system overload resulting in additional costs from replacing blown fuses and additional service calls.

Suffice it to say, the most critical point of information is the peak current requirement (sometimes known as “Starting Current” or “Inrush Current”) of each fixture. It can usually be retrieved from the ballast, driver or fixture specification sheet; sometimes, it must be obtained from the ballast/driver manufacturer. Now you know how to properly select a central lighting inverter system.

## SERVICE AND SUPPORT

### FACTORY STARTUP

All Dual-Lite inverter systems (except LiteGear™ models) are provided standard with factory start-up service by a qualified technician and a two year warranty. A factory trained technician will perform all steps necessary to insure proper operation of the central lighting inverter following installation by a qualified electrical contractor.

### ADDITIONAL TRAINING VISIT

After completing the on-site system start-up, the technician will be available at that time to train owner/user personnel. If the appropriate personnel are not available for on-site training at the completion of the factory start-up procedure, an Additional Training Visit (ATV) option is available at extra cost.

### MONITORING PROGRAM

For additional peace of mind (charge required), an inquiry will be sent to LSN D-Series single-phase inverter systems each month and the results will be reviewed by Dual-Lite’s Technical Support Department. The results of the review will be sent to the designated customer contact with recommendations for corrective action.

### PREVENTIVE MAINTENANCE PROGRAM

All single-phase inverter systems (except LiteGear™ models) qualify for Dual-Lite’s preventive maintenance program. This program provides nine different plan levels including extended warranty programs. Each plan offers a choice of preventive maintenance levels that provide annual visits by a factory trained technician plus ‘call for service’ options.



## *SAFETY . . . RELIABILITY . . . VALUE*

Dual-Lite recognizes that every building is unique and requires its own emergency lighting solution. Whether you need a compact inverter to provide safety for your room, a mid-sized inverter for your entire building, or a large inverter for multiple locations, Dual-Lite has your life safety needs covered. After all, we've been doing this since 1940 and we are the only lighting manufacturer to design and build our own central lighting inverters.



DUAL LITE

Hubbell Lighting, Inc. Life Safety Products • [www.dual-lite.com](http://www.dual-lite.com)  
701 Millennium Boulevard • Greenville, SC 29607  
Telephone: 864-678-1000 Fax: 864-678-1415



A Hubbell Lighting, Inc. brand with representatives' offices in principal cities throughout North America.  
Copyright Hubbell Lighting, Inc., All Rights Reserved. Specifications subject to change without notice.