

# REMOTE CAPACITY

## What is REMOTE CAPACITY?

Remote capacity models provide means for delivering excess DC power (wattage) to additional emergency signage and emergency lighting equipment during power outages. Any combination of remote lamp heads (refer to the remote head section of this catalog) and other equipment such as Dual-Lite Exit Signs with the '-DC' remote operation option (see LX, SE, LN4X or LED Series) may be added to the system as long as the total sum of the remote equipment wattage does not exceed the rated wattage capacity of the source unit.

Example: the AS80 has 65.6 watts of available remote capacity (80 watts minus 14.4 watts (two standard 7.2w integral lamp heads)). Any combination of remote lamp heads and exit signs (with the -DC option) may be added up to the 65.6 watts of extra capacity.

Other Dual-Lite unit equipment with remote capability:  
LZ, LM, TG, ERS, N4X, C1D2, and XPB  
See PSG for specific ordering information

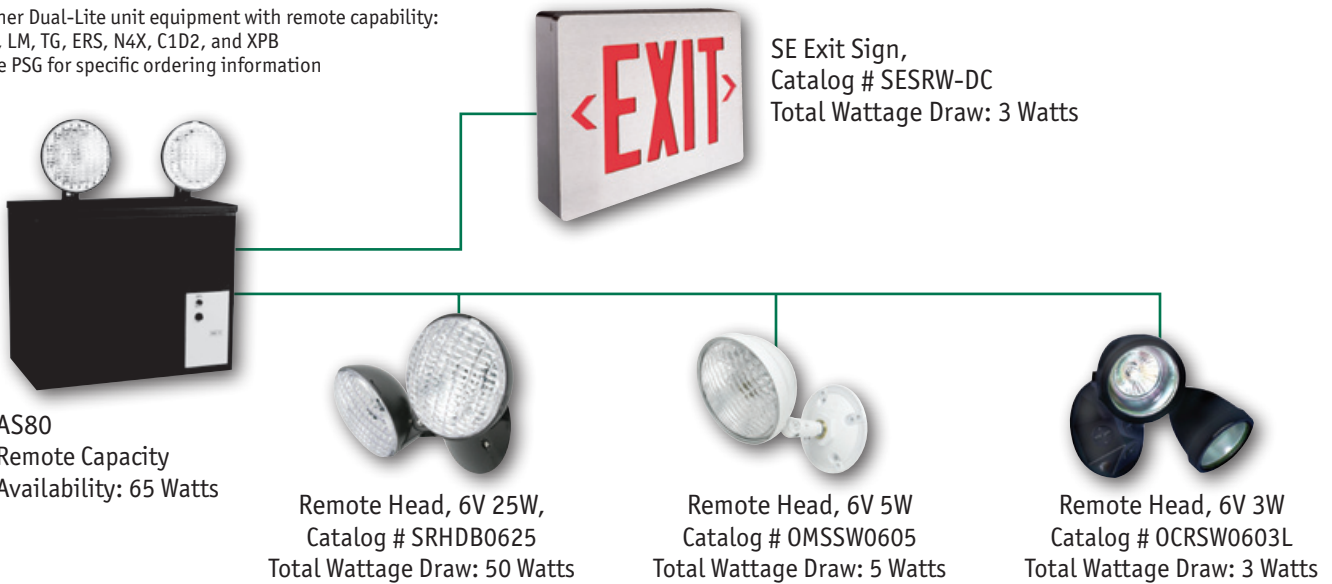

### Wattage Capacity (90 Minute Operation)

AS80 Lighting Unit	80.00
Less two each 7.2 Watts lamp integral to AS80 unit	(14.40)
Less SRHDB0625 Twin Remote Head	(50.00)
Less OMSSW0605 Single Remote Head	(5.00)
Less Exit Sign SESRW-DC	(3.00)
Less Outdoor Remote OCRSW0603L	(3.00)
<b>TOTAL WATTAGE CAPACITY REMAINING*</b>	<b>3.60</b>

\* The National Electric Code limits voltage drop to 5% of nominal. Actual results may vary. Circuit runs must be of sufficient capacity to maintain operating voltage when remote fixtures and/or exit signs are connected to the emergency lighting unit. Refer to the voltage drop tables for sizing and distance of wire run.



# REMOTE HEADS AND FIXTURES

REMOTE HEADS AND FIXTURES



## Indoor Remote Lighting Heads

### SRH Series

Injection molded thermoplastic lamphead/round mounting plate assemblies. Mounts to 3½" octagonal or single gang boxes. For use with most commercial or industrial emergency fixtures. Standard finish is available in white or black. Single and twin lamp fixtures with a choice of incandescent or halogen PAR 36 lamps.

#### ORDERING INFORMATION

SRH			
MODEL	STYLE	FINISH	LAMP
SRH	S Single D Double	W White B Black	<b>0605</b> 6 volt, 5.4 Watts Incandescent <sup>1</sup> <b>0607</b> 6 volt, 7.2 Watts Incandescent <sup>1</sup> <b>0608</b> 6 volt, 8 Watts Halogen <b>0612</b> 6 volt, 12 Watts Halogen <b>0618</b> 6 volt, 18 Watts Incandescent <b>0620</b> 6 volt, 20 Watts Halogen <b>0625</b> 6 volt, 25 Watts Incandescent <b>1207</b> 12 volt, 7.2 Watts Incandescent <sup>1</sup> <b>1208</b> 12 volt, 8 Watts Halogen <b>1212</b> 12 volt, 12 Watts Halogen <b>1218</b> 12 volt, 18 Watts Incandescent <b>1225</b> 12 volt, 25 Watts Incandescent <b>1235</b> 12 volt, 35 Watts Incandescent <b>2409</b> 24 volt, 9 Watts Incandescent <sup>1</sup>

<sup>1</sup>Sealed Beam Type Lamp

## Outdoor Remote Lighting Heads

### OMS Series

Outdoor aluminum spot with sealed lamp and swivel assembly. Furnished with round gasketed aluminum mounting plate. Mounts to 3½" octagonal boxes.



#### ORDERING INFORMATION

OMS			
MODEL	STYLE	FINISH	LAMP
OMS	S Single D Double	W White B Black	<b>0605</b> 6 volt, 5.4 Watts Incandescent <sup>1</sup> <b>0607</b> 6 volt, 7.2 Watts Incandescent <sup>1</sup> <b>0608</b> 6 volt, 8 Watts Halogen <b>0612</b> 6 volt, 12 Watts Halogen <b>0618</b> 6 volt, 18 Watts Incandescent <b>0620</b> 6 volt, 20 Watts Halogen <b>0625</b> 6 volt, 25 Watts Incandescent <b>1207</b> 12 volt, 7.2 Watts Incandescent <sup>1</sup> <b>1208</b> 12 volt, 8 Watts Halogen <b>1212</b> 12 volt, 12 Watts Halogen <b>1218</b> 12 volt, 18 Watts Incandescent <b>1225</b> 12 volt, 25 Watts Incandescent <b>1235</b> 12 volt, 35 Watts Incandescent <b>1250</b> 12 volt, 50 Watts Halogen

<sup>1</sup>Sealed Beam Type Lamp



# REMOTE HEADS AND FIXTURES

## Decorative Indoor Remote Lighting Heads

### CPR Series

Injection molded thermoplastic decorative lamphead and mounting plate assembly. Mounts to 3½" octagonal or single gang boxes. Single and twin lamp fixtures. Choice of 5 watt MR16 Halogen, 10 watt MR16 Halogen, or 3 watt LED MR16. Choice of white or black housing finish.



REMOTE HEADS AND FIXTURES

#### ORDERING INFORMATION

CPR				
MODEL	HEADS	HOUSING FINISH	VOLTS	WATTS
CPR	S Single D Double	W White B Black	06 6 VDC 12 12VDC	05 5 Watt Halogen 10 10 Watt Halogen 03L 3 Watt LED

\*Only with 03L 3Watt LED available

## Decorative Outdoor Remote Lighting Heads

### OCR Series

Outdoor UL Wet Location Listed die cast aluminum lamp head and mounting plate assembly. Mounts to 3½" octagonal or single gang boxes. Single or twin lamp fixtures. Choice of 5 watt MR16 Halogen or 3 watt LED MR16. Choice of white, black, or dark bronze housing finish.



#### ORDERING INFORMATION

OCR				
MODEL	HEADS	HOUSING FINISH	VOLTS	WATTS
OCR	S Single D Double	W White B Black Z Dark Bronze	06 6 VDC 12 12VDC	05 5 Watt Halogen 03L 3 Watt LED

\*Only with 03L 3Watt LED available

# REMOTE HEADS AND FIXTURES

## All Metal Remote Lighting Heads

REMOTE HEADS AND FIXTURES



### AHD

Stamped aluminum housing with metal swivel. Standard finish available in white or black. Choice of incandescent or halogen PAR 36 lamps.

#### ORDERING INFORMATION

AHD			
MODEL	STYLE	FINISH	LAMP
AHD	S Single D Double	W White B Black	<b>0605</b> 6 volt, 5.4 Watts Incandescent <sup>1</sup> <b>0607</b> 6 volt, 7.2 Watts Incandescent <sup>1</sup> <b>0608</b> 6 volt, 8 Watts Halogen <b>0612</b> 6 volt, 12 Watts Halogen <sup>2</sup> <b>0618</b> 6 volt, 18 Watts Incandescent <b>0620</b> 6 volt, 20 Watts Halogen <b>0625</b> 6 volt, 25 Watts Incandescent <b>1207</b> 12 volt, 7.2 Watts Incandescent <sup>1</sup> <b>1208</b> 12 volt, 8 Watts Halogen <b>1212</b> 12 volt, 12 Watts Halogen <sup>2</sup> <b>1218</b> 12 volt, 18 Watts Incandescent <b>1225</b> 12 volt, 25 Watts Incandescent <b>1235</b> 12 volt, 35 Watts Incandescent <b>1250</b> 12 volt, 50 Watts Halogen <b>2407</b> 24 volt, 7.2 Watts Incandescent <sup>1</sup> <b>2413</b> 24 volt, 13 Watts Incandescent <sup>1</sup> <b>2418</b> 24 volt, 18 Watts Incandescent <sup>1</sup> <b>2428</b> 24 volt, 28 Watts Incandescent <sup>1</sup>

<sup>1</sup>Sealed Beam Type Lamp

<sup>2</sup>Not available on Sealed Beam Type Lamps

## Environmental Lighting Head

### GNX Series

Moisture resistant thermoplastic head in black finish with coated lamp terminals and sealed swivel assembly. Furnished with mounting plate. Available with a choice of incandescent or halogen PAR 36 lamps. Matches N4X series units.



Available with shatter containment option. Add "-L" to model number for Sealed Beam Lamps PAR36 only. Example: GNXSB0625-L



#### ORDERING INFORMATION

GNX			-	
MODEL	STYLE	LAMP		OPTIONS
GNX	S Single D Double	<b>0607</b> 6 volt, 7.2 Watts Incandescent <sup>1</sup> <b>0608</b> 6 volt, 8 Watts Halogen <b>0612</b> 6 volt, 12 Watts Halogen <b>0618</b> 6 volt, 18 Watts Incandescent <b>0620</b> 6 volt, 20 Watts Halogen <b>0625</b> 6 volt, 25 Watts Incandescent <b>1208</b> 12 volt, 8 Watts Halogen <b>1209</b> 12 volt, 9 Watts Incandescent <sup>1</sup> <b>1212</b> 12 volt, 12 Watts Halogen <b>1218</b> 12 volt, 18 Watts Incandescent <b>1225</b> 12 volt, 25 Watts Incandescent <b>1235</b> 12 volt, 35 Watts Incandescent		L Shatter Containment <sup>2</sup>

<sup>1</sup>Sealed Beam Type Lamp

<sup>2</sup>Not available on Sealed Beam Type Lamps



# REMOTE HEADS AND FIXTURES



**NEW**  
LED»

## High Performance LED Remote

### PGR Series

The PGR offers LED performance in a remote fixture. Architectural style for indoor or outdoor application. The unit is illuminated by 4 high power LED's arranged so that in the event of 1 or 2 LED failures the unit will continue to operate. The PGN accepts DC voltage which must be supplied from an external 6-12V DC emergency lighting unit. Housing and mounting plate are constructed of 1/8" die-cast aluminum and sealed with a 1/8" closed-cell silicone gasket. Housing finish is powder coated electro-deposition paint available in four colors: dark bronze, white, platinum silver and black. Remote can be wall-mounted by use of a universal molded-in template. Wired from the j-box through the back or through a conduit entry at the top. U.S. Patent No. D627,916

#### Input Power Requirements

12 watts at 6vDC, 13 watts at 12vDC

#### Specific LED information:

Lamp Color: neutral White, 4000K  
Color Rendering Index(CRI): 75  
Total Lamp Output: 445 Lumens min. Initial  
LED Lamplife: 48,000 hrs. at 70% of Initial

#### ORDERING INFORMATION

**PGR**

#### MODEL

PGR

#### HOUSING FINISH

W White

B Black

Z Dark Bronze

P Platinum Silver

## LZ Series Matching Remote Lighting Heads

### LZR

Architectural/commercial design. High performance MR-16 halogen lamps standard or optional energy-saving 3 watt MR-16 LED. Mounts to standard electrical boxes using universal mounting plate provided. Fixture housing mounts to back plate in a choice of four mounting positions. Housings secured using locking screws provided. U.S. Patent Nos. D426,334, D441,475 and 6,045,242.



**NEW**  
LED»

SINGLE REMOTE HEAD - WHITE	SINGLE REMOTE HEAD - BLACK	LAMP VOLTS	LAMP WATTS
LZRSW0605	LZRSB0605	6	5
LZRSW0610	LZRSB0610	6	10
LZRSW1205	LZRSB1205	12	5
LZRSW1210	LZRSB1210	12	10
LZRSW0603L	LZRSB0603L	6	3
LZRSW1203L	LZRSB1203L	12	3

TWIN REMOTE HEAD - WHITE	TWIN REMOTE HEAD - BLACK	LAMP VOLTS	LAMP WATTS
LZRDW0605	LZRDB0605	6	5
LZRDW0610	LZRDB0610	6	10
LZRDW1205	LZRDB1205	12	5
LZRDW1210	LZRDB1210	12	10

### C1D2R/C1D2TR

Suitable for wet and damp location applications. Rated for NEC Class I, Division 2, Groups B, C and D as well as Class I, Zone 2, Group IIA, IIB + Hz environments. Black housing and head assemblies. Single (C1D2R) and twin (C1D2TR) head models.



3R Listed

MODEL NUMBERS		LAMPS*	
SINGLE HEAD HUB LEFT SIDE <sup>1,2</sup>	TWIN HEAD HUB LEFT SIDE <sup>1,2</sup>	VOLTS	WATTS
C1D2R-6V8W	C1D2TR-6V8W	6	8
C1D2R-6V12W	C1D2TR-6V12W	6	12
C1D2R-12V8W	C1D2TR-12V8W	12	8
C1D2R-12V12W	C1D2TR-12V12W	12	12

\* PAR 36 Halogen sealed beam lamps.

<sup>1</sup>Hub Right Side — add "R" to end of model number. Example C1D2R-6V8WR.

<sup>2</sup>Hubs Both Sides — add "F" to end of model number. Example C1D2R-6V8WF.

## Gimbal

### 122

Adjustable (60° max.) recessed mounted fixture. Matte white trim. Dimensions: 8½" dia. x 4½"



INCANDESCENT PAR 36 SEALED BEAM		
MODEL NUMBERS	LAMP VOLTS	LAMP WATTS
122SB-0625	6	25

## Recessed Rectangle

### 124R

Recessed mounted fixture with frosted lens. White trim. Dimensions: 8¾" x 4½" x 4"



DC BAYONET BASE		
MODEL NUMBERS	LAMP VOLTS	LAMP WATTS
124R-0628	6	28
124R-1228	12	28



# UNITS ACCESSORIES

UNIT ACCESSORIES

## Mounting Brackets and Shelves

For mounting of AS Series industrial emergency lighting units.

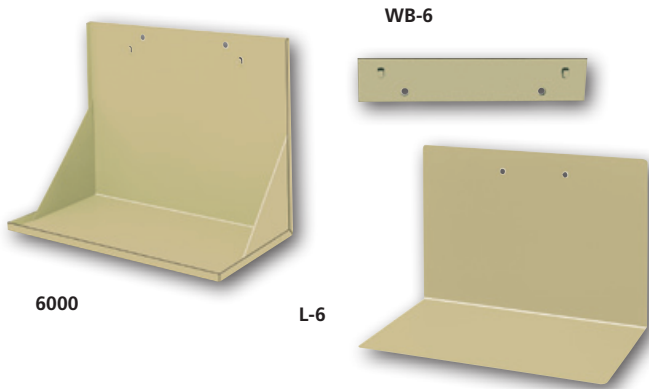

MOUNTING BRACKETS AND SHELVES		
CAT. NO.	TYPE	DIMENSIONS
WB-6	Bracket: use with any AS model	--
6000	Shelf: use with AS180 through AS360	11" H x 14" L x 8 1/8" D
L-6	Shelf: use with AS80 or AS130 only	11" H x 14" L x 8 1/8" D

## Vandal Resistant Shields

For protection against vandalism or accidental damage. Prevents tampering with mountings and lamps.



VANDAL SHIELDS		
CAT. NO.	FOR USE WITH	DIMENSIONS
VRS VRS-4X*	EZ-2, EZ-2R, LZ, LZ High Capacity, and EXT-122-EM-K Series units.	20" L x 10 1/2" H x 7 3/4" D
VRS3	LX and Sempra Series exits.	15 1/2" L x 11 1/2" H x 4 1/2" D

\* VRS-4X supplied with a neoprene wall gasket

## Wire Guards

Offered for most Dual-Lite emergency lights and exits. Constructed of heavy gauge steel, all wire guards are standard with chrome plating. Order as separate line item.

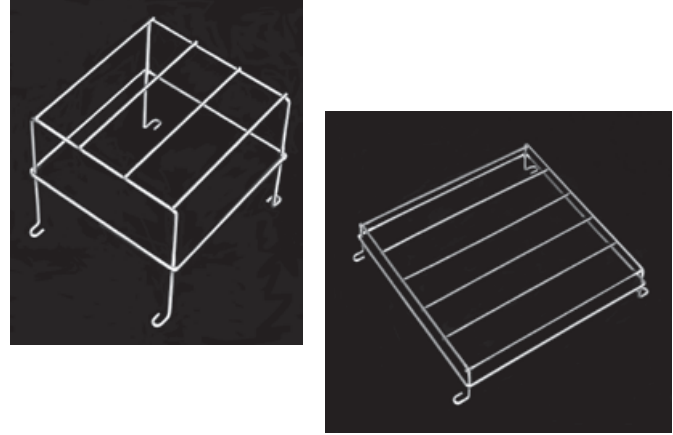

WIRE GUARDS		
CAT. NO.	FOR USE WITH	DIMENSIONS (INSIDE)
WGLZ	LZ Series (except High-Capacity models).	6 1/4" H x 14" L x 4" D
S6WG	Single remote heads.	8" H x 8" L x 8" D
WGEL	EZ-2, EZ-2R, LZ High-Capacity Series and CV Series units. Twin remote heads.	8" H x 20" L x 8" D
40G	LM Series with top mounted heads and NYXC tandem exits. AS Series, N4X Series and CVEC Series (15 and 30 watt models) units.	18 1/2" H x 20" L x 12" D
41G	Delite Cylinder Series and CVEC Series (50 and 100 watt models)	21" H x 23" L x 15" D
WGLX	EXT-122-EM-K units. Wall mount LX, LED and Sempra Series exits.	10" H x 14" L x 2 1/4" D
WGLXC	Ceiling mount LX, LED and Sempra exits	10 3/4" H x 13 3/4" L x 3 1/2" D
WGLXE	End mount LX, LED and Sempra exits	10 1/2" H x 14 1/2" L x 3 1/2" D
WGTW	Wall mount LT, Freedom LED, HCX, NYDC and NYX Series exits	16" H x 20" L x 7 7/8" D
WGTC	Ceiling or end mount LT and Freedom LED Series exits. Ceiling mount NYDC and NYX Series exits	20" H x 15 1/2" L x 8" D
WG-MLT	Lite2 Series units. CMX Series exits	11 5/8" H x 13 3/8" L x 7" D



## Optional Self-Test/Self-Diagnostic Circuitry

SERVICE ALERT CODES	
●	= battery disconnected
● - ●	= battery fault
● - ● - ●	= charger fault
● - ● - ● - ●	= transfer fault
● - ● - ● - ● - ●	= lamp fault



### Self-Testing Electronics System

Technologically advanced self-testing, self-diagnostic electronics provide increased reliability and decreased maintenance.

All Dual-Lite models ordered with the Spectron option provide:

- Visual indication of AC power status
- Visual indication of all self-diagnostic test cycles
- Visual indication of unit malfunctions including:
  - Battery disconnected
  - Battery fault
  - Charger fault
  - Transfer Fault
  - Lamp Fault

### Features

- Meets UL 924 standards for self-testing/self-diagnostic models
- Provides automatic self-diagnostic monitoring and testing of unit operation
- Automatically performs routine maintenance and assures operational readiness at all times
- Monitors charger and lamp operation
- Routine discharge cycles insure optimum battery performance and maximize useful life
- Automatic self-test every 28 days and extended operation self-test every 6 months
- Automatic low voltage disconnect
- Automatic unit transfer in brownout conditions
- Automatic 15-minute time-delay retransfer (TDR) standard on emergency lighting units - allows HID fixtures to come to full brightness before allowing the emergency unit to turn off
- Automatic AC lockout
- Flashing LED indication of unit malfunction
- All detected malfunctions retained in memory until corrected and retested
- Test switch allows system check at any time
- Supports exit sign flashing options

### Test Intervals

...the Spectron self-testing/self-diagnostic system conducts tests to verify proper operation continuously and on monthly and semi-annual intervals

...The Spectron System, as required by the National Electrical Code and the National Fire Protection Association, performs all routine test cycles under full load.

Manual tests may also be performed at any time. A malfunction during any self-test will be indicated by the external status indicators.

### Continuous

...the Spectron system verifies all functions that are critical for emergency operation.

The diagnostic circuit checks functions such as charger operation, battery connection, voltage, and AC supply line. The Spectron system verifies these functions and compares them to predetermined microcontroller parameters. Operation outside these parameters will cause a visual malfunction indication on the unit's Spectron display panel.

### Every 28 days

...the Spectron system conducts a short duration test. This test activates the transfer circuit and discharges the battery, simulating a power failure. The test ensures proper battery capacity and the unit's emergency transfer capability.

### Every 6 Months

...the Spectron system conducts an extended self-diagnostic test cycle with full lamphead illumination. The test simulates a power failure and verifies the unit's operation to code.

### At Any Time

...the Spectron system can test for proper operation. This is accomplished by pushing the manual test switch. The microcontroller will cause the unit to switch to emergency operation mode and a self-diagnostic cycle to begin.

