



WGC42FE

UL 924 Listed Outdoor Emergency Full Cutoff Wall Pack

Catalog Number	
Comments	Type

FEATURES

Application

Dual-Lite Ridgeline® outdoor lighting fixtures provide task and convenience lighting for outdoor entrance/exit ways, perimeter walkways and under canopy installations. Built-in battery packs provide 90 minutes of emergency illumination in the event of a utility power failure.

Construction

The WGC42FE is constructed of die-cast aluminum back housing and backbox, tempered glass lens with a dark bronze finish.

Installation

Universal housing knockouts for mounting to 4" octagon or 4" square electrical boxes in ceiling mount applications. Recommended mounting height is 8' to 15'.

Lamp

Illumination is provided by a 4-pin, 42W low mercury compact fluorescent lamp.

Compliances

UL 924 Listed (emergency models only)

UL 1598 Listed (luminaires)

Wet Location Listed

StarView™ Compliant

NFPA 101 Life Safety Code

NFPA 70 National Electrical Code

Warranty

Three-year warranty for unit, electronics and battery.

Ridgeline®

WGC42FE, Full Cutoff Wall Pack



StarView™
compliant



ORDERING GUIDE

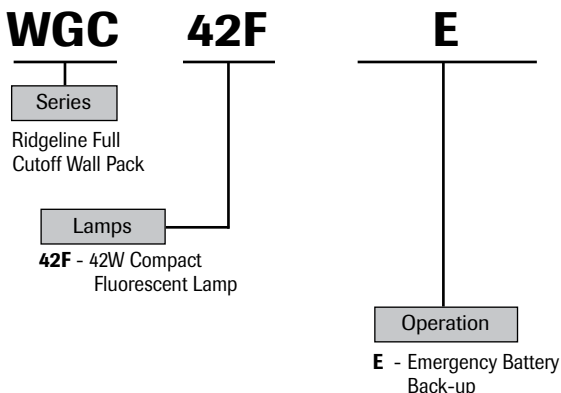



WGC42FE

UL 924 Listed Outdoor Emergency Full Cutoff Wall Pack

SPECIFICATIONS

Electronics

When normal utility supplied power is interrupted, Ridgeline outdoor lighting fixtures will automatically transfer to inverted battery power and provide emergency fixture illumination for 90-minutes. The battery is optimized for use with a low mercury lamp. Following the return of normal utility power, the charging circuit will bring the battery pack to full recharge in 24 hours. A test switch and LED charge indicator light is provided for testing and monitoring of unit performance. Universal input allows operation from either 120 or 277VAC.

Input: 120/277VAC

AC Input Power:

Heater On: 16 watts

Heater Off: 4 watts

RidgeLine Emergency Wallpack Temperature Range:

-20°C to 40°C (-4°F to 104°F)

Normal Lamp Ballast: Per manufacturer's specifications

Emergency Operation Ballast:

- Nickel-cadmium battery
- Solid state battery charger
- Automatic transfer circuit
- High-frequency inverter
- Up to 1250 initial lumens output
- End-of-lamp-life compatible

Shipping Weight: 12.5 lbs.

DIMENSIONS

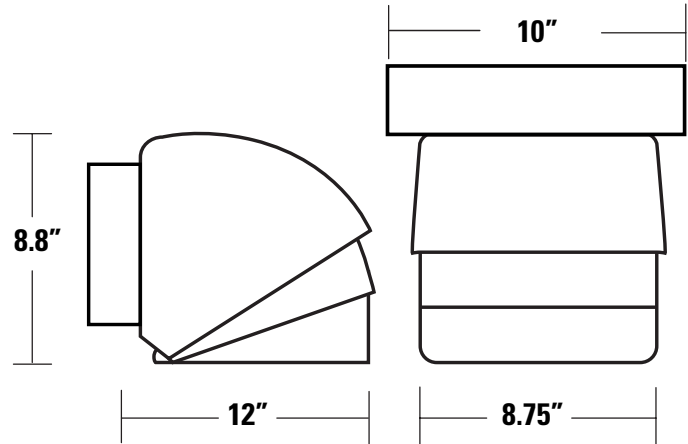

PHOTOMETRY

PHOTOMETRIC FILENAME : WGC-42CFL-E.IES

ISOFOOTCANDLE LINES OF HORIZONTAL ILLUMINANCE

